

INSTALLATION MANUAL

R-410A ZJ SERIES W/SIMPLICITY SE

6-1/2 - 12-1/2 Ton

60 Hertz



TABLE OF CONTENTS

General	2	Auto	37
Installation	5	Free Cooling Operation	37
Preceding Installation	5	Power Exhaust	37
Limitations	5	Airflow Performance	45
Location	7	Air Balance	49
Rigging And Handling	7	Checking Air Quantity	49
Ductwork	15	Operation	52
Side Panels	16	Cooling Sequence Of Operation	52
Condensate Drain	16	Cooling Operation Errors	54
Compressors	17	Electric Heating Sequence Of Operations	55
Filters	17	Electric Heat Operation Errors	55
Power And Control Wiring	17	Gas Heating Sequence Of Operations	56
Optional Electric Heat	31	Gas Heating Operation Errors	56
Optional Gas Heat	31	Start-Up (Cooling)	58
Options/Accessories	33	Start-Up (Gas Heat)	58
Optional Variable Air Volume (VAV)	34	Checking Gas Heat Input	59
Optional Hot Gas Bypass (HGBP)	36	Charging The Unit	61
Economizer Sequences	36	Control Board Navigation Components	61
Dry Bulb Changeover	36	Simplicity™ SE (Smart Equipment) Firmware Version 3. Basic	61
Single Enthalpy Changeover	36	Unit Control Board Navigation Examples	62
Dual Enthalpy Changeover	37	Start-Up Sheet	70

LIST OF TABLES

1 ZJ078-150 Unit Limitations	7	16 Airflow Performance - Side Duct Application	45
2 Weights and Dimensions	8	17 Airflow Performance - Bottom Duct Application	47
3 ZJ078-150 Unit Accessory Weights	9	18 RPM Selection	48
4 ZJ078-150 Unit Physical Dimensions	11	19 Indoor Blower Specifications	49
5 ZJ078-150 Unit Clearances	11	20 Power Exhaust Specifications	49
6 Side Duct Dimensions	14	21 Motor Sheave Datum Diameters	51
7 Control Wire Sizes	20	22 Additional Static Resistance	52
8 Electrical Data	21	23 Electric Heat Limit Setting	55
9 Physical Data	29	24 Electric Heat Anticipator Setpoints	56
10 Electric Heat Minimum Supply Air	31	25 Gas Heat Limit Control Settings	57
11 Gas Pipe Sizing - Capacity of Pipe	32	26 Gas Heat Anticipator Setpoints	58
12 Gas Heat Minimum Supply Air	32	27 Gas Rate Cubic Feet Per Hour	59
13 Simplicity SE Economizer Board Details	38	28 Gas Heat Stages	60
14 Supply Air Limitations	41	29 Simplicity SE UCB Details	64
15 Altitude/Temperature Correction Factors	43	30 Ignition Control Flash Codes	69

LIST OF FIGURES

1 Unit Shipping Bracket	5	19 Discharge Panel In Place	16
2 Condenser Covering	5	20 Save Side Panels For Economizer Hood Tops	16
3 Compressor Section	5	21 Condensate Drain	17
4 Predator® Component Location (ZJ120 Shown)	6	22 Field Wiring Disconnect - Cooling Unit With/Without Electric Heat and All Units With VFD Option	18
5 Unit 4 Point Load Weight	8	23 Field Wiring Disconnect - Cooling Unit With Gas Heat Without VFD Option	19
6 Unit 6 Point Load Weight	8	24 Typical Electronic Thermostat Field Wiring	20
7 Center of Gravity	8	25 Side Entry Gas Piping	31
8 ZJ078-120 Physical Dimensions	9	26 Bottom Entry Gas Piping	32
9 ZJ150 Physical Dimensions	10	27 Simplified VFD Wiring	36
10 ZJ078-150 Unit Bottom Duct Openings	12	28 SE-ECO1001-0 Economizer Controller	38
11 ZJ078-150 Unit Electrical Entry	13	29 Belt Adjustment	42
12 ZJ078-120 Unit Side Duct Openings	13	30 Altitude/Temperature Correction Factors	43
13 ZJ150 Unit Side Duct Openings	14	31 Dry Coil Delta P	50
14 ZJ078-150 Unit Left Duct Opening	14	32 Typical Flame	60
15 ZJ078-150 Roof Curb	15	33 Typical Gas Valve	60
16 ZJ078-150 Transition Roof Curb	15	34 Unit Control Board	64
17 Side Panels With Hole Plugs	16		
18 Return Downflow Plenum With Panel	16		

General

York® Predator® units are single package air conditioners with optional gas heating designed for outdoor installation on a rooftop or slab and for non-residential use. These units can be equipped with factory or field installed electric heaters for heating applications.

These units are completely assembled on rigid, permanently attached base rails. All piping, refrigerant charge, and electrical wiring is factory installed and tested. The units require electric power, gas supply (where applicable), and duct connections. The electric heaters have nickel-chrome elements and utilize single-point power connection.

Safety Considerations

 This is a safety alert symbol. When you see this symbol on labels or in manuals, be alert to the potential for personal injury.

Understand and pay particular attention the signal words **DANGER**, **WARNING** or **CAUTION**.

DANGER indicates an **imminently** hazardous situation, which, if not avoided, **will result in death or serious injury**.

WARNING indicates a **potentially** hazardous situation, which, if not avoided, **could result in death or serious injury**.

CAUTION indicates a potentially hazardous situation, which, if not avoided **may result in minor or moderate injury**. It is also used to alert against unsafe practices and hazards involving only property damage.

WARNING

Improper installation may create a condition where the operation of the product could cause personal injury or property damage. Improper installation, adjustment, alteration, service or maintenance can cause injury or property damage. Refer to this manual for assistance or for additional information, consult a qualified contractor, installer or service agency.

CAUTION

This product must be installed in strict compliance with the installation instructions and any applicable local, state and national codes including, but not limited to building, electrical, and mechanical codes.

WARNING

Before performing service or maintenance operations on unit, turn off main power switch to unit. Electrical shock could cause personal injury. Improper installation, adjustment, alteration, service or maintenance can cause injury or property damage. Refer to this manual. For assistance or additional information consult a qualified installer, service agency or the gas supplier.

CAUTION

This system uses R-410A Refrigerant which operates at higher pressures than R-22. No other refrigerant may be used in this system. Gage sets, hoses, refrigerant containers and recovery systems must be designed to handle R-410A. If you are unsure, consult the equipment manufacturer. Failure to use R-410A compatible servicing equipment may result in property damage or injury.

WARNING

If the information in this manual is not followed exactly, a fire or explosion may result causing property damage, personal injury or loss of life.

Do not store or use gasoline or other flammable vapors and liquids in the vicinity of this or any other appliance.

WHAT TO DO IF YOU SMELL GAS:

- a. Do not try to light any appliance.
- b. Do not touch any electrical switch; do not use any phone in your building.
- c. Immediately call your gas supplier from a neighbor's phone. Follow the gas supplier's instructions.
- d. If you cannot reach your gas supplier, call the fire department.

Installation and service must be performed by a qualified installer, service agency or the gas supplier.

Due to system pressure, moving parts, and electrical components, installation and servicing of air conditioning equipment can be hazardous. Only qualified, trained service personnel should install, repair, or service this equipment. Untrained personnel can perform basic maintenance functions of cleaning coils and filters and replacing filters.

Observe all precautions in the literature, labels, and tags accompanying the equipment whenever working on air conditioning equipment. Be sure to follow all other applicable safety precautions and codes including ANSI Z223.1 or CSA-B149.1- latest edition.

Wear safety glasses and work gloves. Use quenching cloth and have a fire extinguisher available during brazing operations.

Inspection

As soon as a unit is received, it should be inspected for possible damage during transit. If damage is evident, the extent of the damage should be noted on the carrier's freight bill. A separate request for inspection by the carrier's agent should be made in writing.

CAUTION

This product must be installed in strict compliance with the enclosed installation instructions and any applicable local, state and national codes including, but not limited to, building, electrical, and mechanical codes.

The furnace and its individual shut-off valve must be disconnected from the gas supply piping system during any pressure testing at pressures in excess of 1/2 PSIG.

Pressures greater than 1/2 PSIG will cause gas valve damage resulting in a hazardous condition. If it is subjected to a pressure greater than 1/2 PSIG, the gas valve must be replaced.

The furnace must be isolated from the gas supply piping system by closing its individual manual shut-off valve during any pressure testing of the gas supply piping system at test pressures equal to or less than 1/2 PSIG

Reference

Additional information is available in the following reference forms:

- Technical Guide - ZJ078-150, 5167795
- General Installation - ZJ078-150, 5167518
- SSE Control Quick Start Guide - 1136326
- Economizer Accessory -
Downflow Factory Installed
Downflow Field Installed
Horizontal Field Installed
- Motorized Outdoor Air Damper
- Manual Outdoor Air Damper (0-100%)
- Manual Outdoor Air Damper (0-35%)
- Gas Heat Propane Conversion Kit

- Gas Heat High Altitude Kit (Natural Gas)
- Gas Heat High Altitude Kit (Propane)
- -60°F Gas Heat Kit
- Electric Heater Accessory 50" cabinet

Renewal Parts

Contact your local York® parts distribution center for authorized replacement parts.

Approvals

Design certified by CSA as follows:

1. For use as a cooling only unit, cooling unit with supplemental electric heat or a forced air furnace.
2. For outdoor installation only.
3. For installation on combustible material and may be installed directly on combustible flooring or, in the U.S., on wood flooring or Class A, Class B or Class C roof covering materials.
4. For use with natural gas (convertible to LP with kit).

CAUTION

This product must be installed in strict compliance with the enclosed installation instructions and any applicable local, state, and national codes including, but not limited to, building, electrical, and mechanical codes.

WARNING

Improper installation may create a condition where the operation of the product could cause personal injury or property damage.

CAUTION

This system uses R-410A Refrigerant which operates at higher pressures than R-22. No other refrigerant may be used in this system.

Nomenclature

6.5-12.5 ZJ Ton York® Model Number Nomenclature

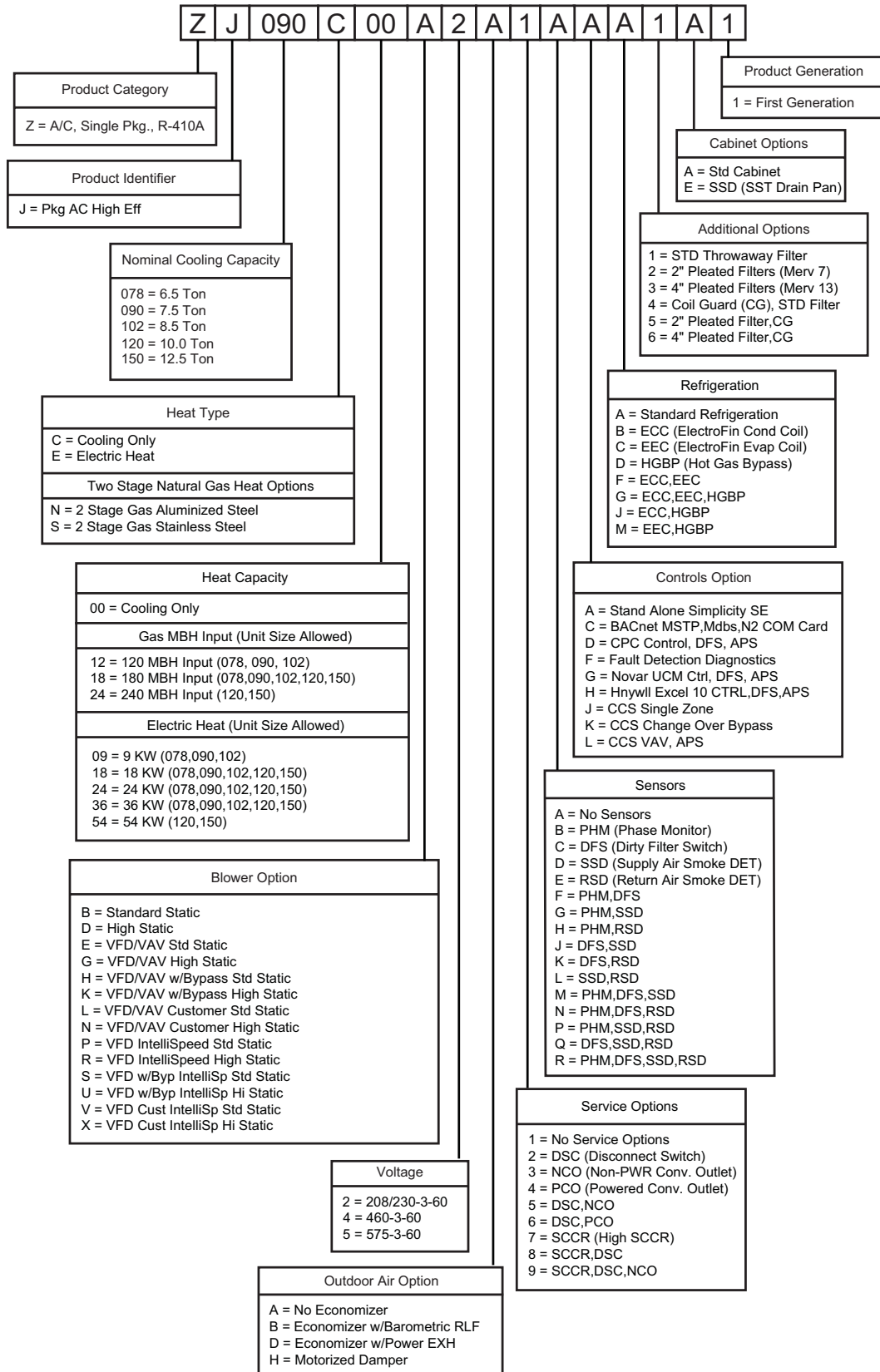

Installation

Installation Safety Information

Read these instructions before continuing this appliance installation. This is an outdoor combination heating and cooling unit. The installer must assure that these instructions are made available to the consumer and with instructions to retain them for future reference.

1. Refer to the unit rating plate for the approved type of gas for this product.
2. Install this unit only in a location and position as specified on Page 7 of these instructions.
3. Never test for gas leaks with an open flame. Use commercially available soap solution made specifically for the detection of leaks when checking all connections, as specified on Pages 5, 33, 33 and 58 of these instructions.
4. Always install furnace to operate within the furnace's intended temperature-rise range with the duct system and within the allowable external static pressure range, as specified on the unit name/rating plate, specified on Page 60 of these instructions.
5. This equipment is not to be used for temporary heating of buildings or structures under construction.

WARNING

FIRE OR EXPLOSION HAZARD

Failure to follow the safety warning exactly could result in serious injury, death or property damage.

Never test for gas leaks with an open flame. use a commercially available soap solution made specifically for the detection of leaks to check all connections. A fire or explosion may result causing property damage, personal injury or loss of life.

Preceding Installation

1. Remove the two screws holding the brackets in the front, rear and compressor side fork-lift slots.



Figure 1: Unit Shipping Bracket

2. Turn each bracket toward the ground and the protective plywood covering will drop to the ground.
3. Remove the condenser coil external protective covering prior to operation.

4. Remove the toolless doorknobs and instruction packet prior to installation.

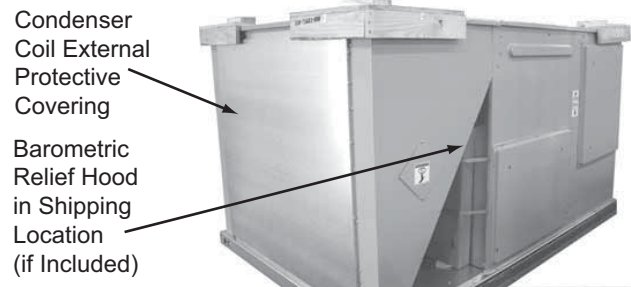

Figure 2: Condenser Covering

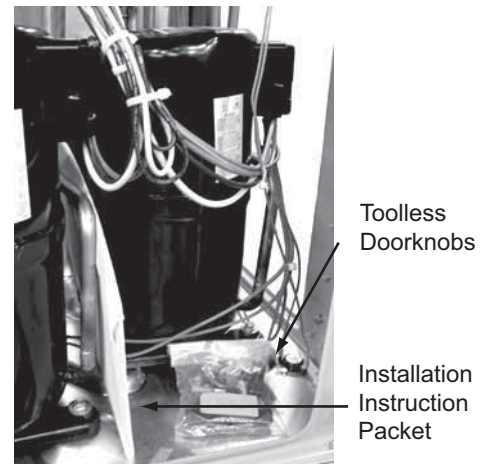

Figure 3: Compressor Section

5. If a factory option convenience outlet is installed, the weatherproof outlet cover must be field installed. The cover shall be located behind the filter access panel. To install the cover, remove the shipping label covering the convenience outlet, follow the instructions on the back of the weatherproof cover box, and attach the cover to the unit using the (4) screws provided.

CAUTION

208/230-3-60 and 380/415-3-50 units with factory installed Powered Convenience Outlet Option are wired for 230v and 415v power supply respectively. Change tap on transformer for 208-3-60 or 380-3-50 operation. See unit wiring diagram.

Limitations

These units must be installed in accordance with the following:

In U.S.A.:

1. National Electrical Code, ANSI/NFPA No. 70 - Latest Edition
2. National Fuel Gas Code, ANSI Z223.1 - Latest Edition

3. Gas-Fired Central Furnace Standard, ANSI Z21.47 Latest Edition
4. Local building codes, and
5. Local gas utility requirements

In Canada:

1. Canadian Electrical Code, CSA C22.1
2. Installation Codes, CSA - B149.1.
3. Local plumbing and waste water codes, and
4. Other applicable local codes.

Refer to unit application data found in this document.

After installation, gas fired units must be adjusted to obtain a temperature rise within the range specified on the unit rating plate.

If components are to be added to a unit to meet local codes, they are to be installed at the dealer's and/or customer's expense.

Size of unit for proposed installation should be based on heat loss/heat gain calculation made according to the methods of Air Conditioning Contractors of America (ACCA).

This furnace is not to be used for temporary heating of buildings or structures under construction.

⚠ CAUTION

The Simplicity® SE control board used in this product will effectively operate the cooling system down to 0°F when this product is applied in a comfort cooling application for people. An economizer is typically included in this type of application. When applying this product for process cooling applications (computer rooms, switchgear, etc.), please reference applications bulletin AE-011-07 or call the applications department for Unitary Products @ 1-877-UPG-SERV for guidance. Additional accessories may be needed for stable operation at temperatures below 30° F.

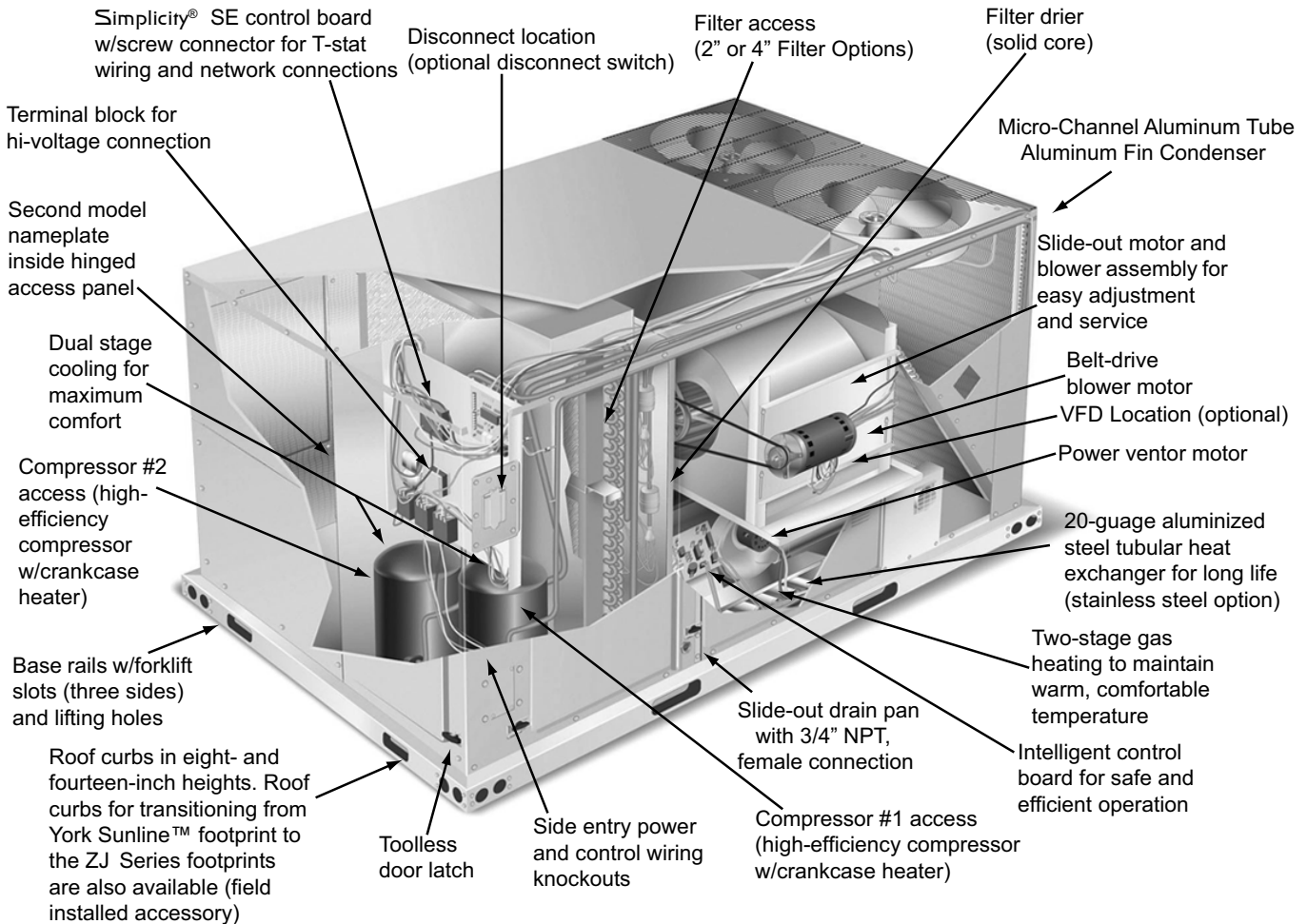

Figure 4: Predator® Component Location (ZJ120 Shown)

Table 1: ZJ078-150 Unit Limitations

Size (Tons)	Model	Unit Voltage	Unit Limitations		
			Applied Voltage		Outdoor DB Temp
			Min	Max	Max (°F)
078 (6.5)	ZJ	208/230-3-60	187	252	125
		460-3-60	432	504	125
		575-3-60	540	630	125
090 (7.5)	ZJ	208/230-3-60	187	252	125
		460-3-60	432	504	125
		575-3-60	540	630	125
102 (8.5)	ZJ	208/230-3-60	187	252	125
		460-3-60	432	504	125
		575-3-60	540	630	125
120 (10)	ZJ	208/230-3-60	187	252	125
		460-3-60	432	504	125
		575-3-60	540	630	125
150 (12.5)	ZJ	208/230-3-60	187	252	125
		460-3-60	432	504	125
		575-3-60	540	630	125

Location

Use the following guidelines to select a suitable location for these units:

- Unit is designed for outdoor installation only.
- Condenser coils must have an unlimited supply of air. Where a choice of location is possible, position the unit on either north or east side of building.
- Suitable for mounting on roof curb.
- For ground level installation, use a level concrete slab with a minimum thickness of 4 inches. The length and width should be at least 6 inches greater than the unit base rails. Do not tie slab to the building foundation.
- Roof structures must be able to support the weight of the unit and its options/accessories. Unit must be installed on a solid, level roof curb or appropriate angle iron frame.
- Maintain level tolerance to 1/2" across the entire width and length of unit.

WARNING

Excessive exposure of this furnace to contaminated combustion air may result in equipment damage or personal injury. Typical contaminants include: permanent wave solution, chlorinated waxes and cleaners, chlorine based swimming pool chemicals, water softening chemicals, carbon tetrachloride, Halogen type refrigerants, cleaning solvents (e.g. perchloroethylene), printing inks, paint removers, varnishes, hydrochloric acid, cements and glues, antistatic fabric softeners for clothes dryers, masonry acid washing materials.

Clearances

All units require particular clearances for proper operation and service. Installer must make provisions for adequate combustion and ventilation air in accordance with section 5.3 of Air for Combustion and Ventilation of the National Fuel Gas Code, ANSI Z223.1 – Latest Edition (in U.S.A.), or Sections 7.2, 7.3, or 7.4 of Gas Installation Codes, CSA-B149.1 (in Canada) - Latest Edition, and/or applicable provisions of the local building codes. Refer to Table 5 for clearances required for combustible construction, servicing, and proper unit operation.

WARNING

Do not permit overhanging structures or shrubs to obstruct condenser air discharge outlet, combustion air inlet or vent outlets.

Rigging And Handling

Exercise care when moving the unit. Do not remove any packaging until the unit is near the place of installation. Rig the unit by attaching chain or cable slings to the lifting holes provided in the base rails. Spreader bars, whose length exceeds the largest dimension across the unit, **MUST** be used across the top of the unit.

CAUTION

If a unit is to be installed on a roof curb other than a York® roof curb, gasketing must be applied to all surfaces that come in contact with the unit underside.

CAUTION

Before lifting, make sure the unit weight is distributed equally on the rigging cables so it will lift evenly.

Units may be moved or lifted with a forklift. Slotted openings in the base rails are provided for this purpose.

LENGTH OF FORKS MUST BE A MINIMUM OF 60 INCHES.

CAUTION

All panels must be secured in place when the unit is lifted.

The condenser coils should be protected from rigging cable damage with plywood or other suitable material.

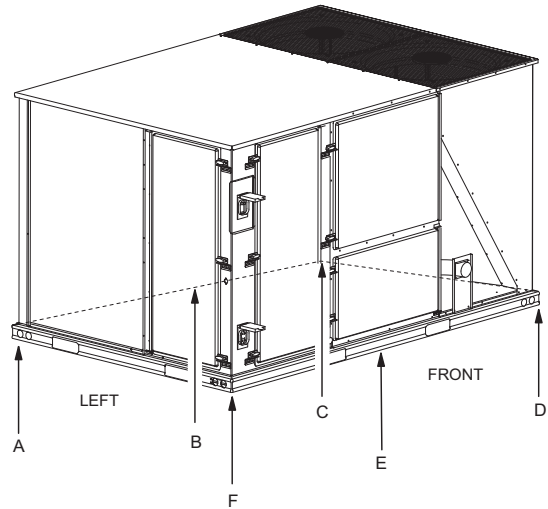

Figure 6: Unit 6 Point Load Weight

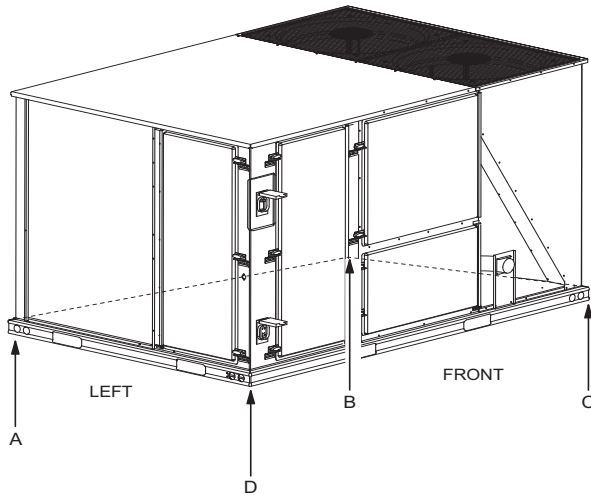

Figure 5: Unit 4 Point Load Weight

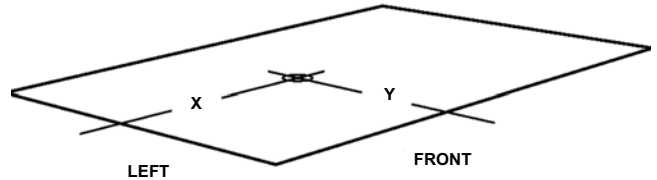

Figure 7: Center of Gravity

Table 2: Weights and Dimensions

Size (Tons)	Model	Weight (lbs.)		Center of Gravity		4 Point Load Location (lbs.)				6 Point Load Location (lbs.)					
		Shipping	Operating	X	Y	A	B	C	D	A	B	C	D	E	F
078 (6.5)	ZJ	1035	1030	39	25	245	191	260	333	170	144	122	167	195	232
090 (7.5)	ZJ	1055	1050	39	25	250	195	265	340	174	146	125	170	199	236
102 (8.5)	ZJ	1065	1060	38	24	247	184	268	360	173	141	117	171	206	253
120 (10)	ZJ	1075	1070	39	24	245	191	278	357	170	143	122	178	209	248
150 (12.5)	ZJ	1285	1280	48	24	240	281	410	350	156	173	192	280	252	227

Table 3: ZJ078-150 Unit Accessory Weights

Unit Accessory	Weight (lbs.)	
	Shipping	Operating
Economizer	90	85
Power Exhaust	40	35
Electric Heat ¹	49	49
Gas Heat ²	110	110
Variable Frequency Drive ³	30	30

1. Weight given is for the maximum heater size available (54KW).
2. Weight given is for the maximum number of tube heat exchangers available (8 tube).
3. Weight includes mounting hardware, controls and manual bypass option.

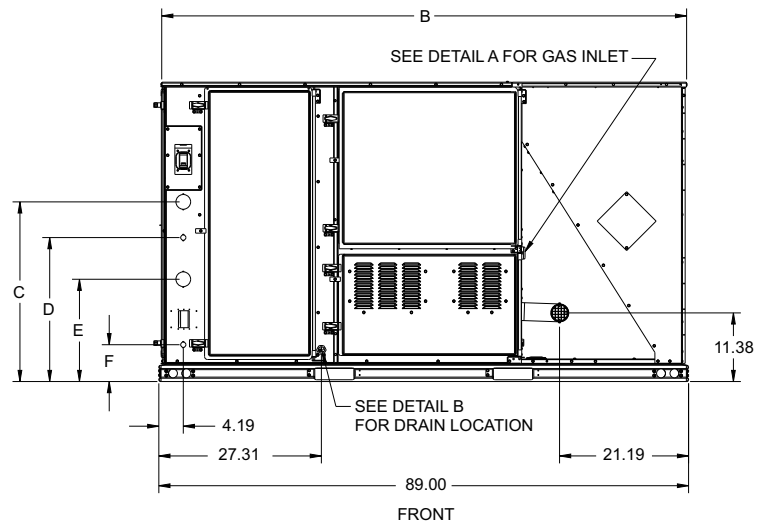
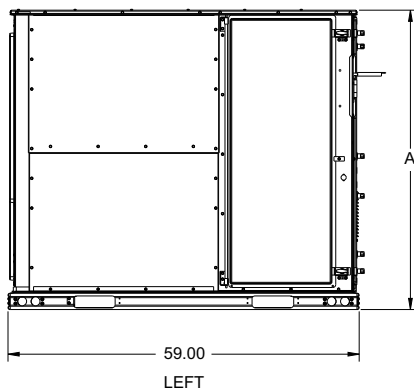
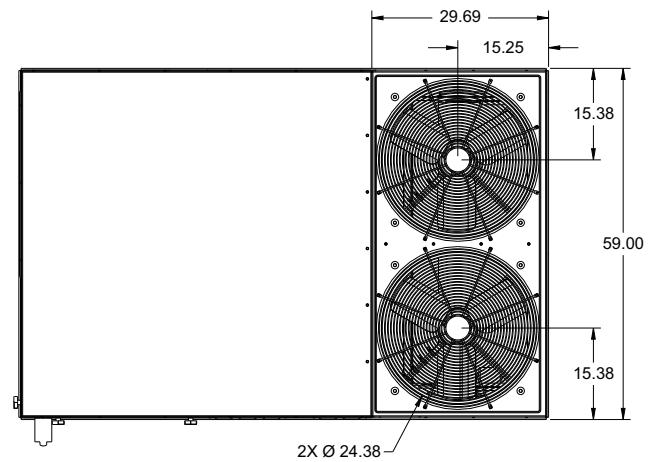
**Figure 8: ZJ078-120 Physical Dimensions**

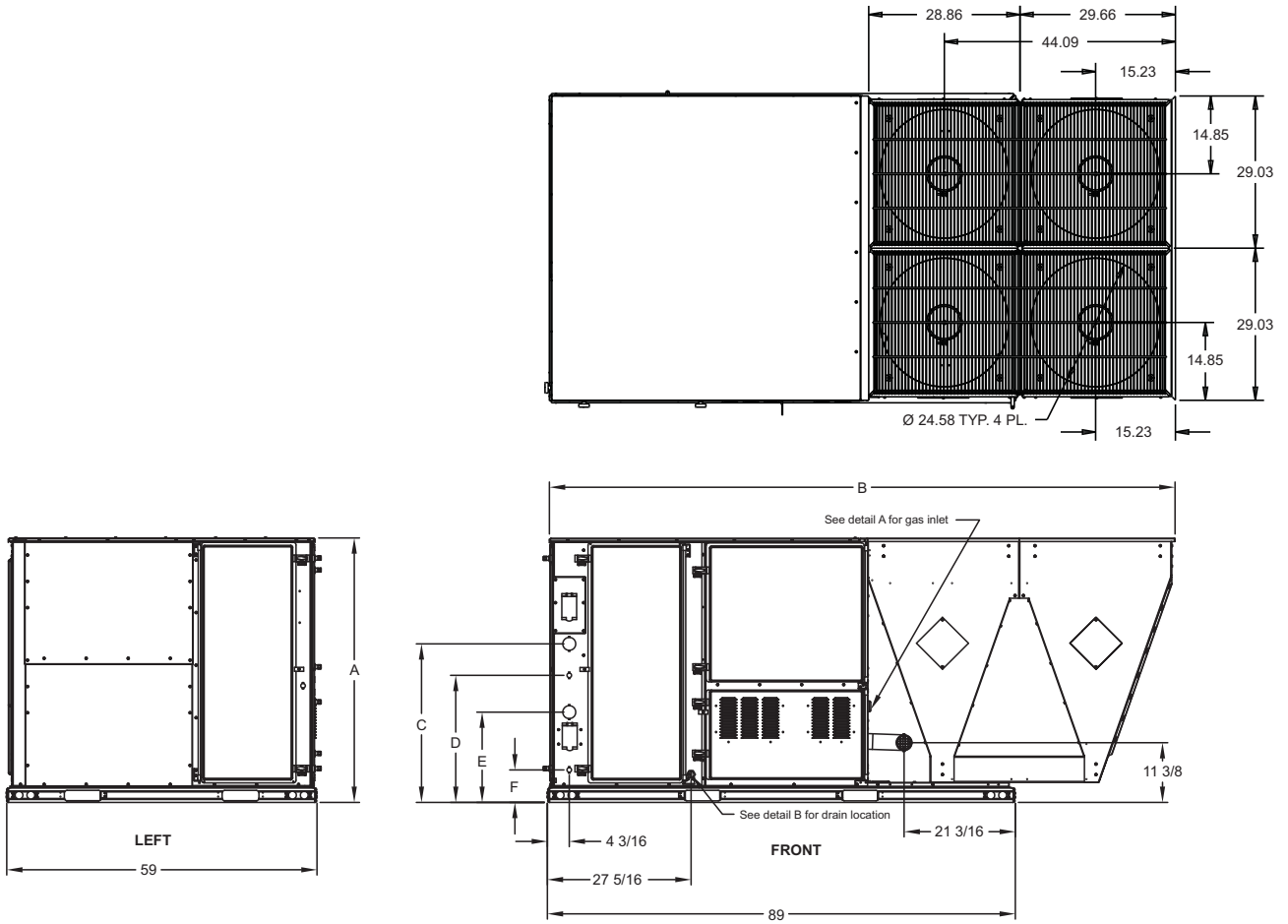
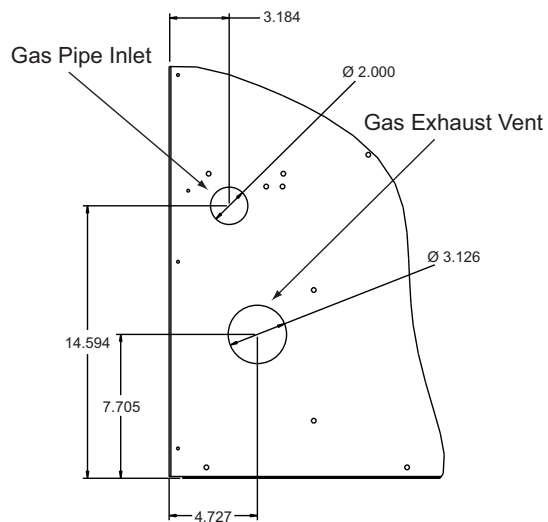
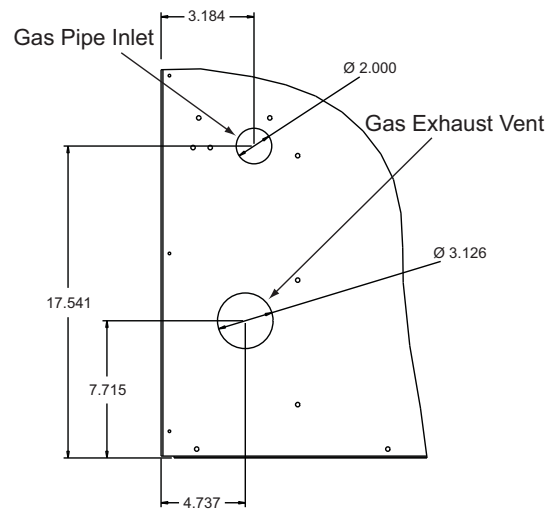
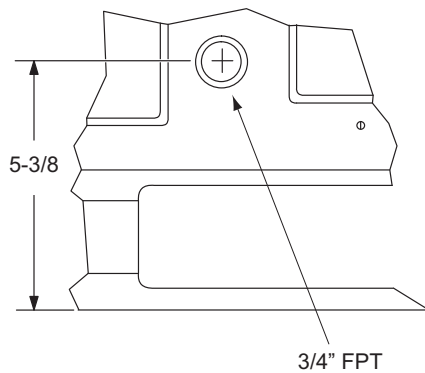

Figure 9: ZJ150 Physical Dimensions

Table 4: ZJ078-150 Unit Physical Dimensions

Unit Model Number	Dimension (in.)					
	A	B	C	D	E	F
ZJ078	50 3/4	89	30 3/16	24 3/16	17 3/16	6 3/16
ZJ090	50 3/4	89	30 3/16	24 3/16	17 3/16	6 3/16
ZJ102	50 3/4	89	30 3/16	24 3/16	17 3/16	6 3/16
ZJ120	50 3/4	89	30 3/16	24 3/16	17 3/16	6 3/16
ZJ150	50 3/4	119 1/2	30 3/16	24 3/16	17 3/16	6 3/16

Detail A**42" CABINET****50 3/4" CABINET****Detail B****Table 5: ZJ078-150 Unit Clearances**

Direction	Distance (in.)	Direction	Distance (in.)
Top ¹	72	Right	12
Front	36	Left	36
Rear	36	Bottom ²	0

- Units must be installed outdoors. Over hanging structure or shrubs should not obscure condenser air discharge outlet.
- Units may be installed on combustible floors made from wood or class A, B or C roof covering materials.

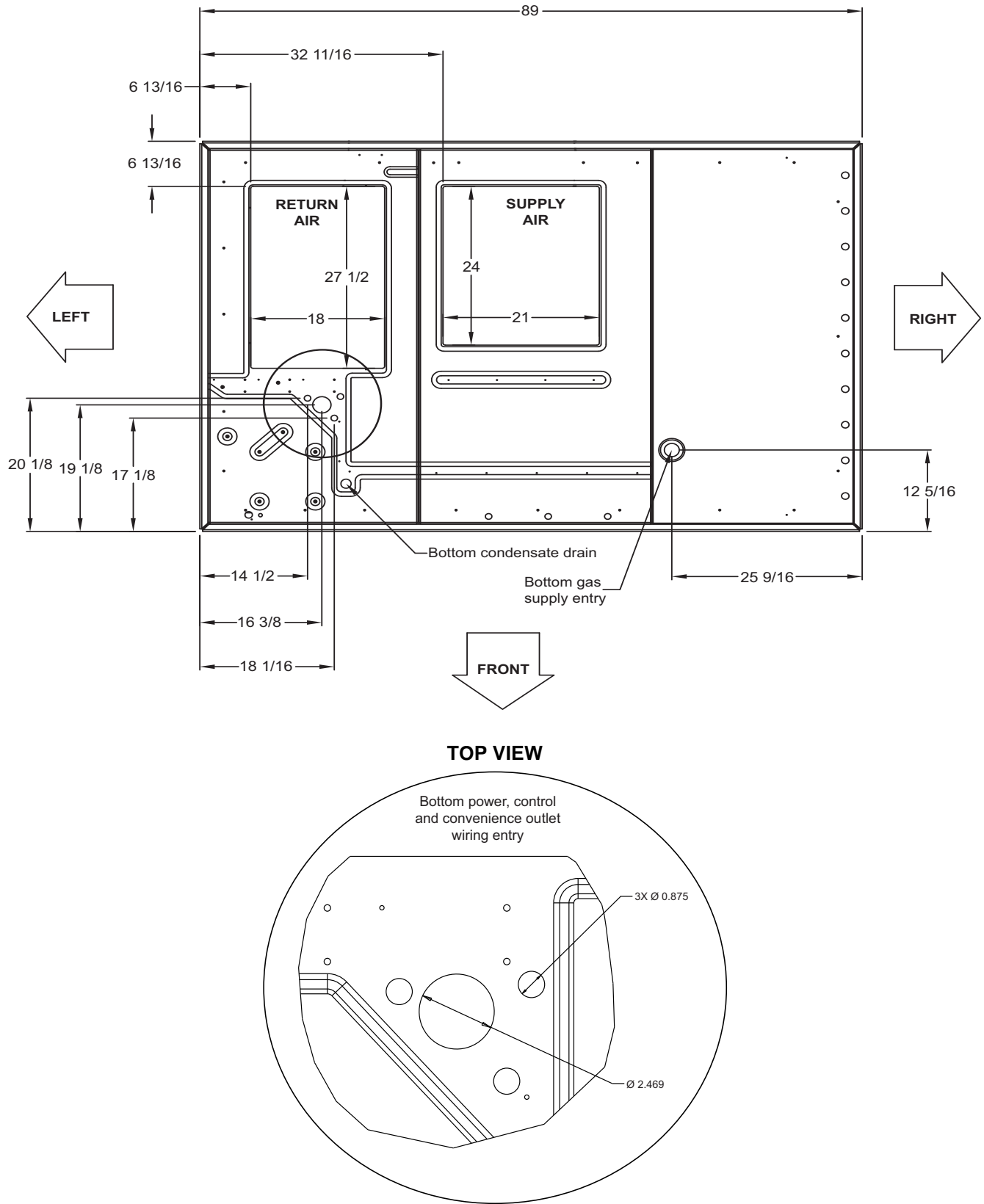

Figure 10: ZJ078-150 Unit Bottom Duct Openings

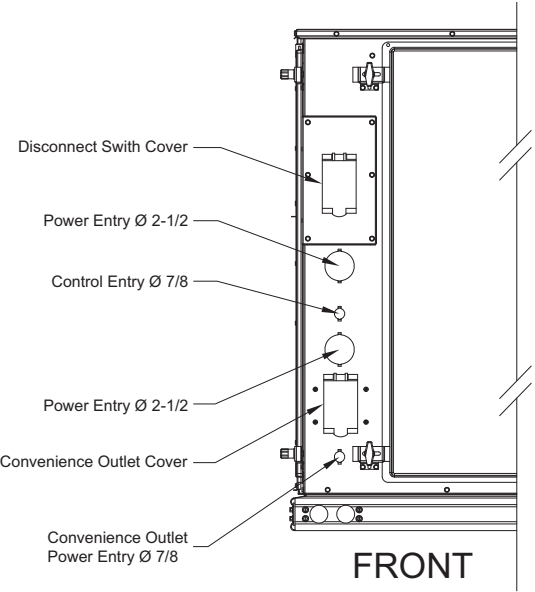

Figure 11: ZJ078-150 Unit Electrical Entry

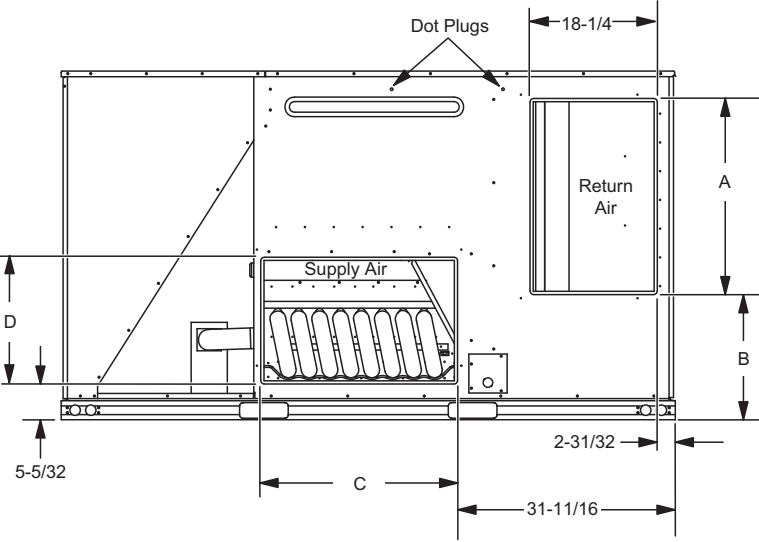

Figure 12: ZJ078-120 Unit Side Duct Openings

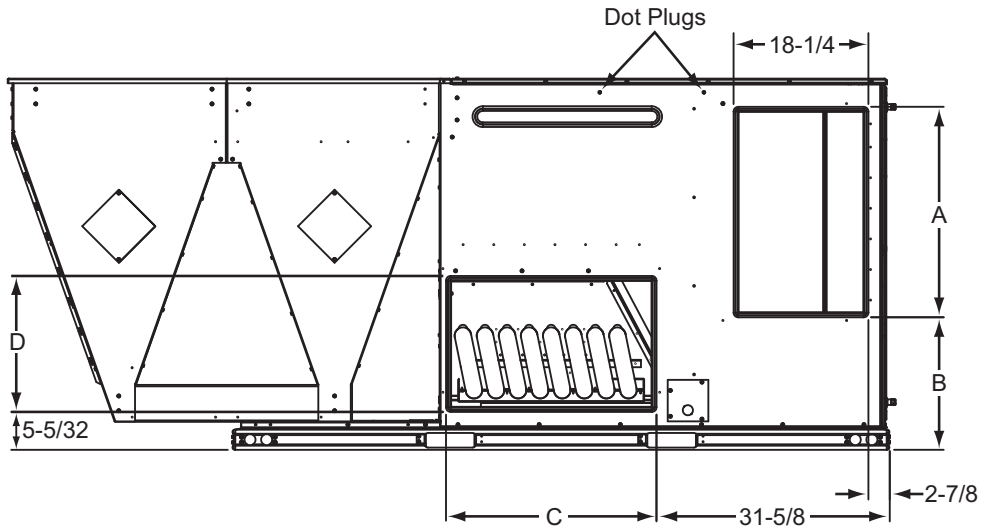

Figure 13: ZJ150 Unit Side Duct Openings

Table 6: Side Duct Dimensions

Unit Model Number	Dimension (in.)			
	A	B	C	D
ZJ078	28 1/4	18 1/16	28 1/4	18 1/4
ZJ090	28 1/4	18 1/16	28 1/4	18 1/4
ZJ102	28 1/4	18 1/16	28 1/4	18 1/4
ZJ120	28 1/4	18 1/16	28 1/4	18 1/4
ZJ150	28 1/4	18 1/16	28 1/4	18 1/4

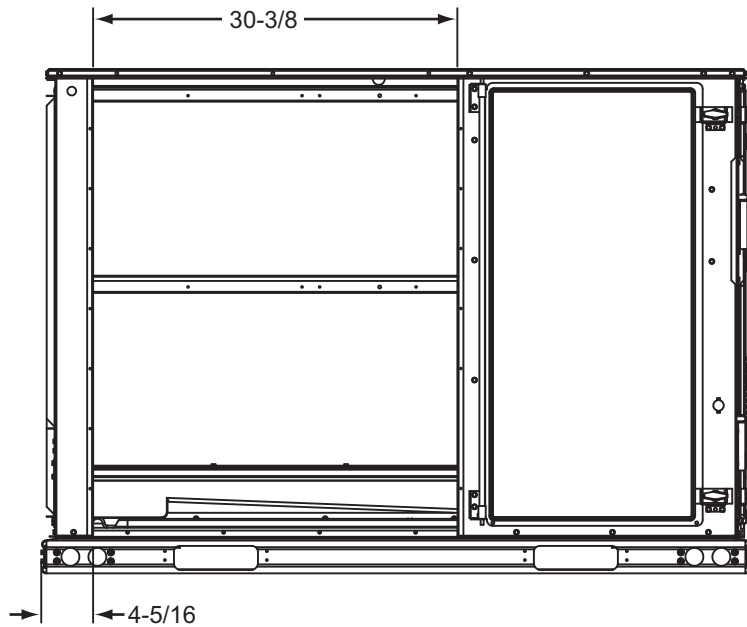

Figure 14: ZJ078-150 Unit Left Duct Opening

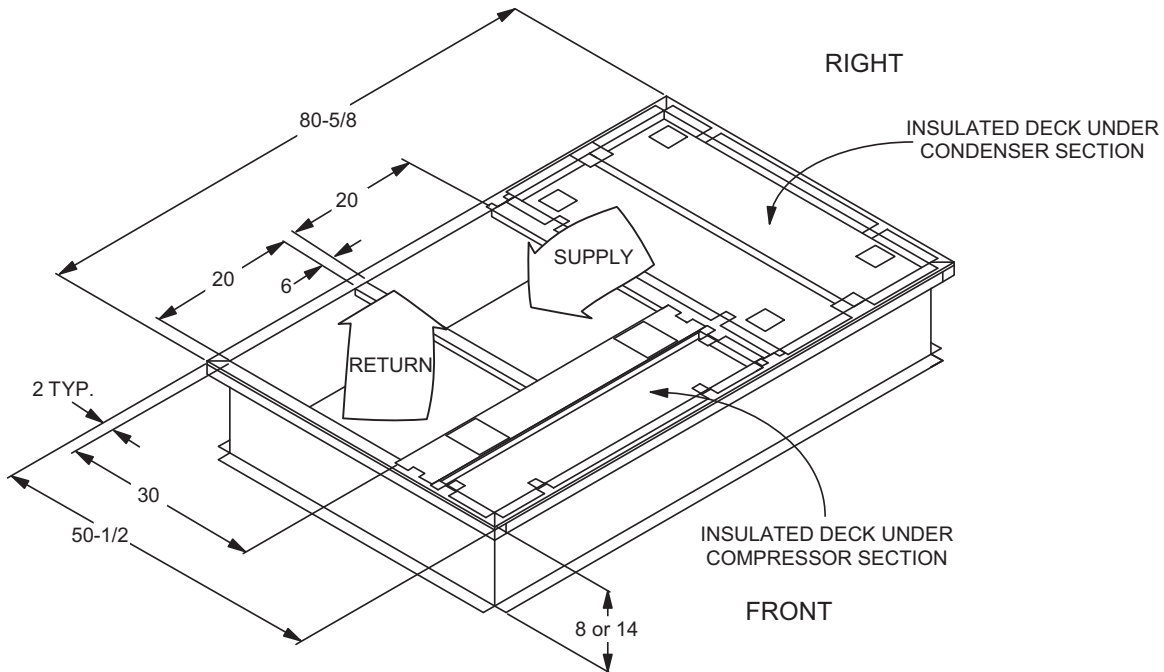

Figure 15: ZJ078-150 Roof Curb

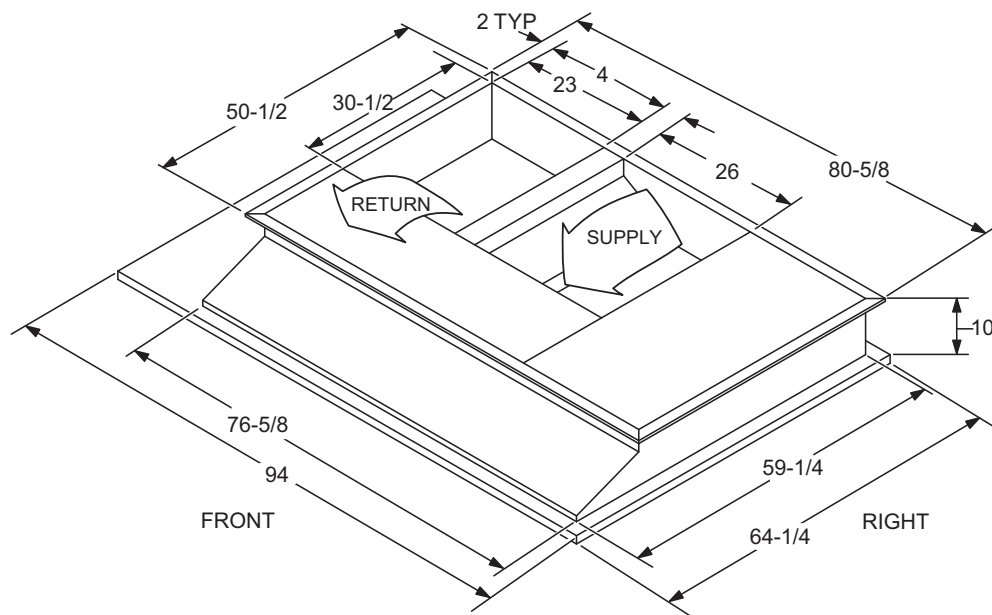

Figure 16: ZJ078-150 Transition Roof Curb

Ductwork

Ductwork should be designed and sized according to the methods in Manual D of the Air Conditioning Contractors of America (ACCA) or as recommended by any other recognized authority such as ASHRAE or SMACNA.

A closed return duct system should be used. This will not preclude use of economizers or outdoor fresh air intake. The

supply and return air duct connections at the unit should be made with flexible joints to minimize noise.

The supply and return air duct systems should be designed for the CFM and static pressure requirements of the job. They should NOT be sized to match the dimensions of the duct connections on the unit.

Refer to Figure 10 for bottom air duct openings. Refer to Figures 12, 13 and Table 6 for side air duct openings.

Duct Covers

Units are shipped with the side duct openings covered and a covering over the bottom of the unit. For bottom duct application, no duct cover changes are necessary. For side duct application, remove the side duct covers and install over the bottom duct openings. The panels removed from the side duct connections are designed to be reused by securing each panel to its respective down flow opening. But keep in mind that the supply panel is installed with the painted surface UP, facing the heat exchanger, while the return panel is installed with the painted surface DOWN, facing the down flow duct opening. The supply panel is secured with the bracket (already in place from the factory) and two screws. It's a snug fit for the panel when sliding it between the heat exchanger and unit bottom, but there is room. The return panel is secured with four screws.

CAUTION

When fastening ductwork to side duct flanges on unit, insert screws through duct flanges only. DO NOT insert screws through casing. Outdoor ductwork must be insulated and water-proofed.



Figure 17: Side Panels With Hole Plugs

NOTE: Orientation. Panel is “insulation” side up.



Figure 18: Return Downflow Plenum With Panel

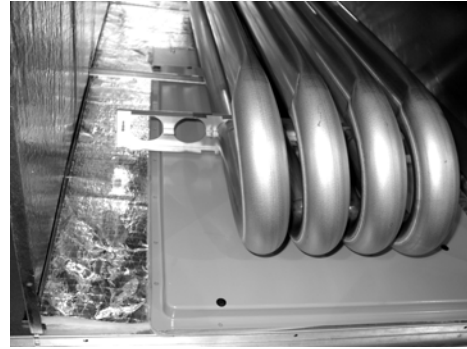

Figure 19: Discharge Panel In Place

Side Panels

Units are shipped with side panels to cover the area where an economizer or motorized damper may be installed. These panels must be saved and used as tops for the Economizer rain hoods (See Figure 20)



Figure 20: Save Side Panels For Economizer Hood Tops

Condensate Drain

The side condensate drain is reversible and maybe re-oriented to the rear of the cabinet to facilitate condensate piping. A condensate drain connection is available through the base pan for piping inside the roof curb. Trap the connection per Figure 21. The trap and drain lines should be protected from freezing.

Plumbing must conform to local codes. Use a sealing compound on male pipe threads. Install condensate drain line from the 3/4 inch NPT female connection on the unit to an open drain.

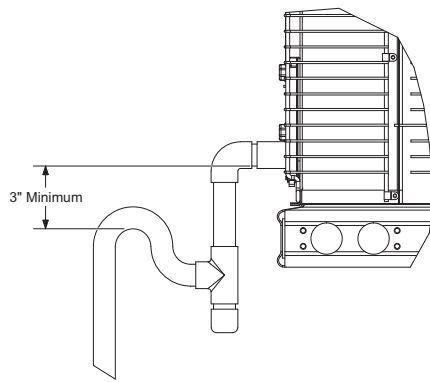

Figure 21: Condensate Drain

Compressors

The scroll compressor used in this product is specifically designed to operate with R-410A Refrigerant and cannot be interchanged.

CAUTION

This system uses R-410A Refrigerant which operates at higher pressures than R-22. No other refrigerant may be used in this system.

The compressor also uses a polyolester (POE oil), Mobil 3MA POE. This oil is extremely hygroscopic, meaning it absorbs water readily. POE oil can absorb 15 times as much water as other oils designed for HCFC and CFC refrigerants. Take all necessary precautions to avoid exposure of the oil to the atmosphere.

CAUTION

Do not leave the system open to the atmosphere. Unit damage could occur due to moisture being absorbed by the **POE oil** in the system. This type of oil is highly susceptible to moisture absorption

POE (polyolester) compressor lubricants are known to cause long term damage to some synthetic roofing materials.

CAUTION

Exposure, even if immediately cleaned up, may cause embrittlement (leading to cracking) to occur in one year or more. When performing any service that may risk exposure of compressor oil to the roof, take precautions to protect roofing.

Procedures which risk oil leakage include, but are not limited to, compressor replacement, repairing refrigerant leaks, replacing refrigerant components such as filter drier, pressure switch, metering device or coil.

Units are shipped with compressor mountings which are factory-adjusted and ready for operation.

CAUTION

Do not loosen compressor mounting bolts.

Filters

Two-inch filters are supplied with each unit. One-inch filters may be used with no modification to the filter racks. Filters must always be installed ahead of evaporator coil and must be kept clean or replaced with same size and type. Dirty filters reduce the capacity of the unit and result in frosted coils or safety shutdown. Refer to physical data tables, for the number and size of filters needed for the unit. The unit should not be operated without filters properly installed.

CAUTION

Make sure that panel latches are properly positioned on the unit to maintain an airtight seal.

Power And Control Wiring

Field wiring to the unit, fuses, and disconnects must conform to provisions of National Electrical Code (NEC), ANSI/NFPA No. 70 – Latest Edition (in U.S.A.), current Canadian Electrical Code C221, and/or local ordinances. The unit must be electrically grounded in accordance with NEC and CEC as specified above and/or local codes.

Voltage tolerances which must be maintained at the compressor terminals during starting and running conditions are indicated on the unit Rating Plate and Table 1.

CAUTION

208/230-3-60 and 380/415-3-50 units control transformers are factory wired for 230v and 415v power supply respectively. Change tap on transformer for 208-3-60 or 380-3-50 operation. See unit wiring diagram.

The internal wiring harnesses furnished with this unit are an integral part of the design certified unit. Field alteration to comply with electrical codes should not be required. If any of the wire supplied with the unit must be replaced, replacement wire must be of the type shown on the wiring diagram and the same minimum gauge as the replaced wire.

A disconnect must be utilized for these units. Factory installed disconnects are available. If installing a disconnect (field supplied or York International® supplied accessory), refer to Figure 4 for the recommended mounting location.

CAUTION

Avoid damage to internal components if drilling holes for disconnect mounting.

NOTE: Since not all local codes allow the mounting of a disconnect on the unit, please confirm compliance with local code before mounting a disconnect on the unit.

Electrical line must be sized properly to carry the load. USE COPPER CONDUCTORS ONLY. Each unit must be wired with a separate branch circuit fed directly from the meter panel and properly fused.

Refer to Figures 22, 23, 24 and 24 for typical field wiring and to the appropriate unit wiring diagram mounted inside control doors for control circuit and power wiring information.

CAUTION

When connecting electrical power and control wiring to the unit, water-proof connectors must be used so that water or moisture cannot be drawn into the unit during normal operation. The above water-proofing conditions will also apply when installing a field supplied disconnect switch.

Power Wiring Detail

Units are factory wired for the voltage shown on the unit nameplate. Refer to Electrical Data Table 8 to size power wiring, fuses, and disconnect switch.

Power wiring is brought into the unit through the side of the unit or the basepan inside the curb.

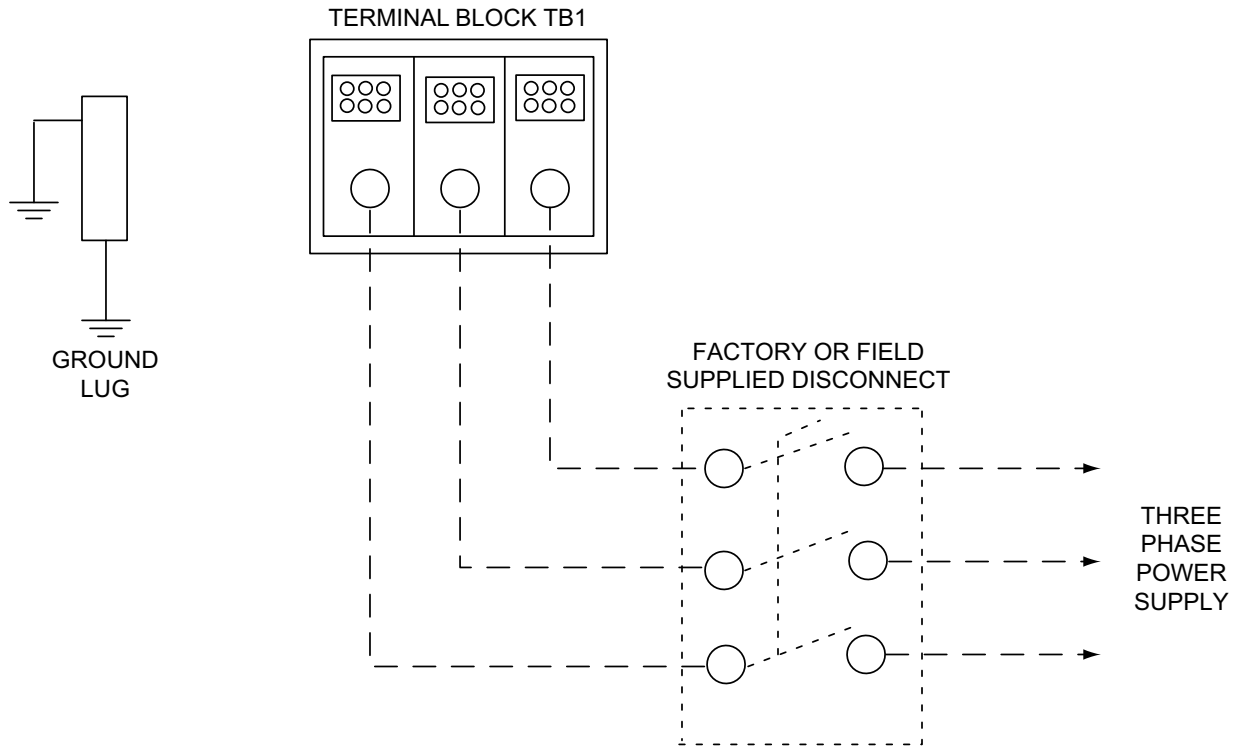

Figure 22: Field Wiring Disconnect - Cooling Unit With/Without Electric Heat and All Units With VFD Option

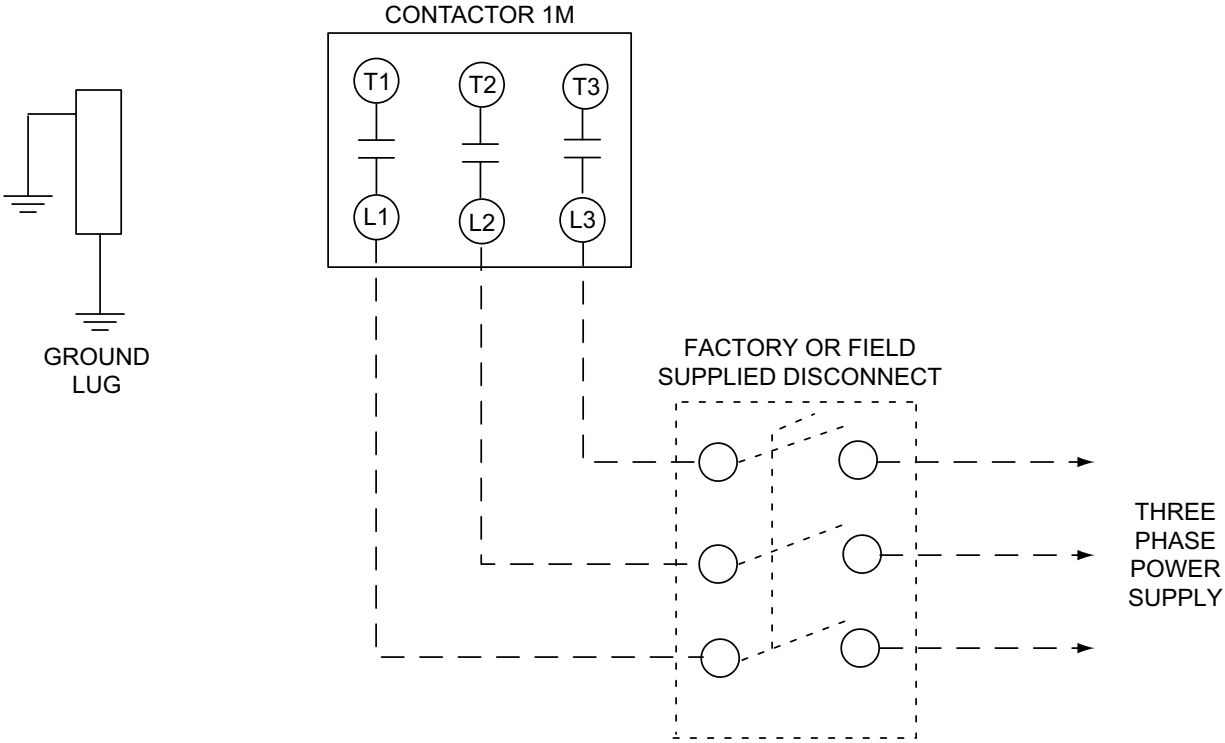

Figure 23: Field Wiring Disconnect - Cooling Unit With Gas Heat Without VFD Option

Thermostat Wiring (Not applicable to units with VFD)

The thermostat should be located on an inside wall approximately 56 inch above the floor where it will not be subject to drafts, sun exposure or heat from electrical fixtures or appliances. Follow the manufacturer's instructions enclosed with thermostat for general installation procedure. Seven (7) color-coded, insulated wires should be used to connect the

thermostat to the unit. Refer to Table 7 for control wire sizing and maximum length.

Table 7: Control Wire Sizes

Wire Size	Maximum Length ¹
18 AWG	150 Feet

1. From the unit to the thermostat and back to the unit.

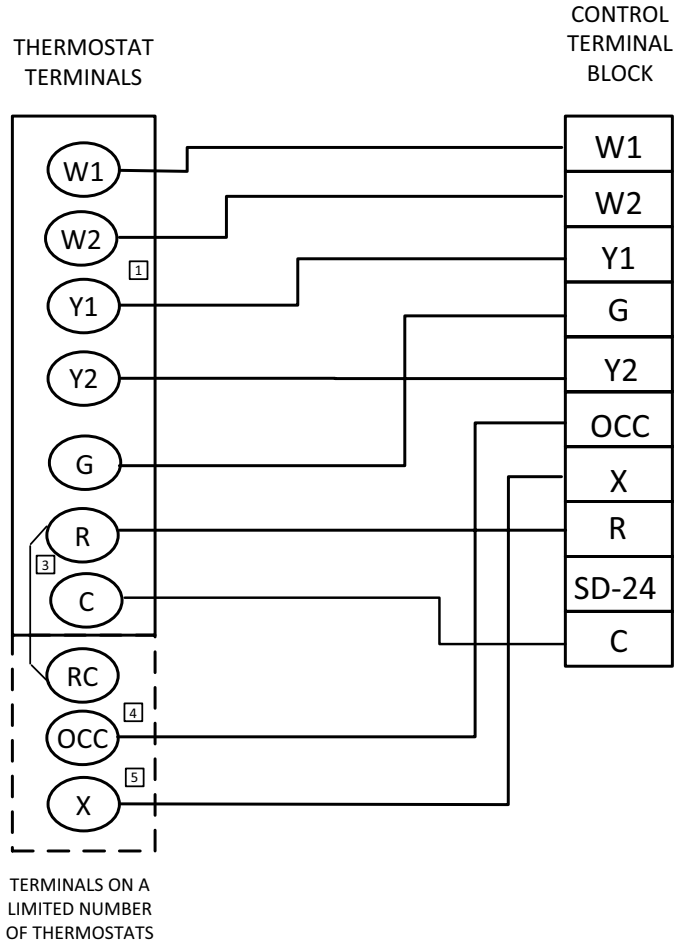

- 1 Second stage heating not required on single stage heating units.
- 2 Jumper is required if there is no Smoke Detector circuit.
- 3 Jumper is required for any combination of R, RC, or RH.
- 4 OCC is an output from the thermostat to indicate the Occupied condition.
- 5 X is an input to the thermostat to display Error Status conditions.

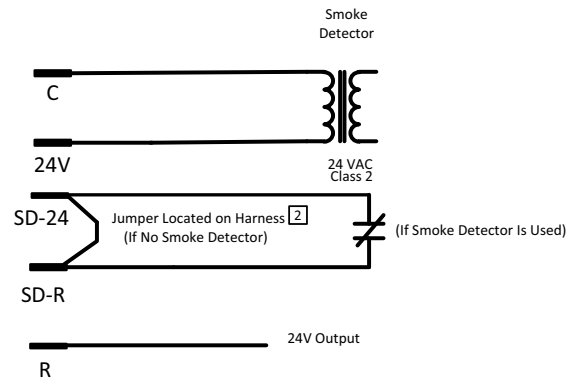

Figure 24: Typical Electronic Thermostat Field Wiring

⚠ CAUTION

208/230-3-60 and 380/415-3-50 units control transformers are factory wired for 230v and 415v power supply respectively. Change tap on transformer for 208-3-60 or 380-3-50 operation. See unit wiring diagram.

Table 8: Electrical Data
ZJ078-150 Standard Motor - Without Powered Convenience Outlet

Size (Tons)	Volt	Compressors (each)			OD Fan Motors (each)	Supply Blower Motor	Pwr Exh Motor	Pwr Conv Outlet	Electric Heat Option				MCA ¹ (Amps)	MCA ¹ w/Pwr Exh (Amps)	Max Fuse ^{2/} Breaker ³ Size (Amps)	Max Fuse ^{2/} Breaker ³ Size w/ Pwr Exh (Amps)
		RLA	LRA	MCC	FLA	FLA	FLA	FLA	Model	kW	Stages	Amps				
078 (6.5)	208	9.3	68.0	14.5	2.1	5.2	5.5	0.0	None	-	-	-	30.3	35.8	35	45
									E09	6.8	1	18.9	30.3	37.0	35	45
									E18	13.5	2	37.5	53.3	60.2	60	70
									E24	18.0	2	50.0	69.0	75.8	70	80
									E36	25.5	2	70.8	95.0	101.9	100	110
	230	9.3	68.0	14.5	2.1	5.2	5.5	0.0	None	-	-	-	30.3	35.8	35	45
									E09	9.0	1	21.7	33.6	40.4	35	45
									E18	18.0	2	43.3	60.6	67.5	70	70
									E24	24.0	2	57.7	78.7	85.5	80	90
									E36	34.0	2	81.8	108.7	115.6	110	125
	460	4.9	34.0	7.6	1.3	2.6	2.2	0.0	None	-	-	-	16.1	18.3	20	20
									E09	9.0	1	10.8	16.8	19.5	20	20
									E18	18.0	2	21.7	30.3	33.1	35	35
									E24	24.0	2	28.9	39.3	42.1	40	45
									E36	34.0	2	40.9	54.4	57.1	60	60
	575	3.8	28.0	6.0	0.7	2.0	1.8	0.0	None	-	-	-	11.9	13.7	15	15
									E09	9.0	1	8.7	13.3	15.6	15	20
									E18	18.0	2	17.3	24.2	26.4	25	30
									E24	24.0	2	23.1	31.4	33.6	35	35
									E36	34.0	2	32.7	43.4	45.6	45	50
090 (7.5)	208	11.9	88.0	18.5	3.0	5.2	5.5	0.0	None	-	-	-	38.0	43.5	45	50
									E09	6.8	1	18.9	38.0	43.5	45	50
									E18	13.5	2	37.5	53.3	60.2	60	70
									E24	18.0	2	50.0	69.0	75.8	70	80
									E36	25.5	2	70.8	95.0	101.9	100	110
	230	11.9	88.0	18.5	3.0	5.2	5.5	0.0	None	-	-	-	38.0	43.5	45	50
									E09	9.0	1	21.7	38.0	43.5	45	50
									E18	18.0	2	43.3	60.6	67.5	70	70
									E24	24.0	2	57.7	78.7	85.5	80	90
									E36	34.0	2	81.8	108.7	115.6	110	125
	460	5.2	44.0	8.1	1.6	2.6	2.2	0.0	None	-	-	-	17.5	19.7	20	20
									E09	9.0	1	10.8	17.5	19.7	20	20
									E18	18.0	2	21.7	30.3	33.1	35	35
									E24	24.0	2	28.9	39.3	42.1	40	45
									E36	34.0	2	40.9	54.4	57.1	60	60
	575	4.8	36.0	7.5	1.4	2.0	1.8	0.0	None	-	-	-	15.5	17.3	20	20
									E09	9.0	1	8.7	15.5	17.3	20	20
									E18	18.0	2	17.3	24.2	26.4	25	30
									E24	24.0	2	23.1	31.4	33.6	35	35
									E36	34.0	2	32.7	43.4	45.6	45	50
102 (8.5)	208	12.2	88.0	19.0	3.0	6.8	5.5	0.0	None	-	-	-	40.3	45.8	50	50
									E09	6.8	1	18.9	40.3	45.8	50	50
									E18	13.5	2	37.5	55.3	62.2	60	70
									E24	18.0	2	50.0	71.0	77.8	80	80
									E36	25.5	2	70.8	97.0	103.9	100	110
	230	12.2	88.0	19.0	3.0	6.8	5.5	0.0	None	-	-	-	40.3	45.8	50	50
									E09	9.0	1	21.7	40.3	45.8	50	50
									E18	18.0	2	43.3	62.6	69.5	70	70
									E24	24.0	2	57.7	80.7	87.5	90	90
									E36	34.0	2	81.8	110.7	117.6	125	125
	460	5.8	44.0	9.0	1.6	3.4	2.2	0.0	None	-	-	-	19.7	21.9	25	25
									E09	9.0	1	10.8	19.7	21.9	25	25
									E18	18.0	2	21.7	31.3	34.1	35	35
									E24	24.0	2	28.9	40.3	43.1	45	45
									E36	34.0	2	40.9	55.4	58.1	60	60
	575	4.4	36.0	5.5	1.4	2.4	1.8	0.0	None	-	-	-	15.0	16.8	15	20
									E09	9.0	1	8.7	15.0	16.8	15	20
									E18	18.0	2	17.3	24.7	26.9	25	30
									E24	24.0	2	23.1	31.9	34.1	35	35
									E36	34.0	2	32.7	43.9	46.1	45	50

ZJ078-150 Standard Motor - Without Powered Convenience Outlet (Continued)

Size (Tons)	Volt	Compressors (each)			OD Fan Motors (each)	Supply Blower Motor	Pwr Exh Motor	Pwr Conv Outlet	Electric Heat Option				MCA ¹ (Amps)	MCA ¹ w/Pwr Exh (Amps)	Max Fuse ² / Breaker ³ Size (Amps)	Max Fuse ² / Breaker ³ Size w/ Pwr Exh (Amps)
		RLA	LRA	MCC	FLA	FLA	FLA	FLA	Model	kW	Stages	Amps				
120 (10)	208	16.0	110.0	24.9	3.0	6.8	5.5	0.0	None	-	-	-	48.9	54.4	60	70
									E18	13.5	2	37.5	55.3	62.2	60	70
									E24	18.0	2	50.0	71.0	77.8	80	80
									E36	25.5	2	70.8	97.0	103.9	100	110
									E54	40.6	2	112.7	149.4	156.2	150	175
	230	16.0	110.0	24.9	3.0	6.8	5.5	0.0	None	-	-	-	48.9	54.4	60	70
									E18	18.0	2	43.3	62.6	69.5	70	70
									E24	24.0	2	57.7	80.7	87.5	90	90
									E36	34.0	2	81.8	110.7	117.6	125	125
									E54	54.0	2	129.9	138.4	145.3	150	175
	460	7.8	52.0	12.1	1.6	3.4	2.2	0.0	None	-	-	-	24.2	26.4	30	30
									E18	18.0	2	21.7	31.3	34.1	35	35
									E24	24.0	2	28.9	40.3	43.1	45	45
									E36	34.0	2	40.9	55.4	58.1	60	60
									E54	54.0	2	65.0	69.2	72.0	80	80
	575	5.7	38.9	8.9	1.4	2.4	1.8	0.0	None	-	-	-	17.9	19.7	20	25
									E18	18.0	2	17.3	24.7	26.9	25	30
									E24	24.0	2	23.1	31.9	34.1	35	35
									E36	34.0	2	32.7	43.9	46.1	45	50
									E54	54.0	2	52.0	55.0	57.2	60	60
150 (12.5)	208	23.1	160.0	36.0	2.1	9.6	5.5	0.0	None	-	-	-	70.0	75.5	90	90
									E18	13.5	2	37.5	70.0	75.5	90	90
									E24	18.0	2	50.0	74.5	81.3	90	90
									E36	25.5	2	70.8	100.5	107.4	110	110
									E54	40.6	2	112.7	152.9	159.7	175	175
	230	23.1	160.0	36.0	2.1	9.6	5.5	0.0	None	-	-	-	70.0	75.5	90	90
									E18	18.0	2	43.3	70.0	75.5	90	90
									E24	24.0	2	57.7	84.2	91.0	90	100
									E36	34.0	2	81.8	114.2	121.1	125	125
									E54	54.0	2	129.9	141.9	148.8	175	175
	460	12.2	87.0	19.0	1.3	4.7	2.2	0.0	None	-	-	-	37.2	39.4	45	50
									E18	18.0	2	21.7	37.2	39.4	45	50
									E24	24.0	2	28.9	42.0	44.7	45	50
									E36	34.0	2	40.9	57.0	59.7	60	60
									E54	54.0	2	65.0	70.8	73.6	80	80
	575	8.7	62.0	13.5	0.7	3.6	1.8	0.0	None	-	-	-	25.8	27.6	30	35
									E18	18.0	2	17.3	26.2	28.4	30	35
									E24	24.0	2	23.1	33.4	35.6	35	40
									E36	34.0	2	32.7	45.4	47.6	50	50
									E54	54.0	2	52.0	56.5	58.7	70	70

1. Minimum Circuit Ampacity.
2. Dual Element, Time Delay Type.
3. HACR type per NEC.

ZJ078-150 Hi Static Motor - Without Powered Convenience Outlet

Size (Tons)	Volt	Compressors (each)			OD Fan Motors (each)	Supply Blower Motor	Pwr Exh Motor	Pwr Conv Outlet	Electric Heat Option				MCA ¹ (Amps)	MCA ¹ w/Pwr Exh (Amps)	Max Fuse ² / Breaker ³ Size (Amps)	Max Fuse ² / Breaker ³ Size w/ Pwr Exh (Amps)
		RLA	LRA	MCC	FLA	FLA	FLA	FLA	Model	kW	Stages	Amps				
078 (6.5)	208	9.3	68.0	14.5	2.1	6.8	5.5	0.0	None	-	-	-	31.9	37.4	40	45
									E09	6.8	1	18.9	32.1	39.0	40	45
									E18	13.5	2	37.5	55.3	62.2	60	70
									E24	18.0	2	50.0	71.0	77.8	80	80
									E36	25.5	2	70.8	97.0	103.9	100	110
	230	9.3	68.0	14.5	2.1	6.8	5.5	0.0	None	-	-	-	31.9	37.4	40	45
									E09	9.0	1	21.7	35.6	42.4	40	45
									E18	18.0	2	43.3	62.6	69.5	70	70
									E24	24.0	2	57.7	80.7	87.5	90	90
									E36	34.0	2	81.8	110.7	117.6	125	125
	460	4.9	34.0	7.6	1.3	3.4	2.2	0.0	None	-	-	-	16.9	19.1	20	20
									E09	9.0	1	10.8	17.8	20.5	20	25
									E18	18.0	2	21.7	31.3	34.1	35	35
									E24	24.0	2	28.9	40.3	43.1	45	45
									E36	34.0	2	40.9	55.4	58.1	60	60
	575	3.8	28.0	6.0	0.7	2.4	1.8	0.0	None	-	-	-	12.3	14.1	15	15
									E09	9.0	1	8.7	13.8	16.1	15	20
									E18	18.0	2	17.3	24.7	26.9	25	30
									E24	24.0	2	23.1	31.9	34.1	35	35
									E36	34.0	2	32.7	43.9	46.1	45	50
090 (7.5)	208	11.9	88.0	18.5	3.0	9.6	5.5	0.0	None	-	-	-	42.4	47.9	50	50
									E09	6.8	1	18.9	42.4	47.9	50	50
									E18	13.5	2	37.5	58.8	65.7	60	70
									E24	18.0	2	50.0	74.5	81.3	80	90
									E36	25.5	2	70.8	100.5	107.4	110	110
	230	11.9	88.0	18.5	3.0	9.6	5.5	0.0	None	-	-	-	42.4	47.9	50	50
									E09	9.0	1	21.7	42.4	47.9	50	50
									E18	18.0	2	43.3	66.1	73.0	70	80
									E24	24.0	2	57.7	84.2	91.0	90	100
									E36	34.0	2	81.8	114.2	121.1	125	125
	460	5.2	44.0	8.1	1.6	4.7	2.2	0.0	None	-	-	-	19.6	21.8	20	25
									E09	9.0	1	10.8	19.6	22.2	20	25
									E18	18.0	2	21.7	32.9	35.7	35	40
									E24	24.0	2	28.9	42.0	44.7	45	45
									E36	34.0	2	40.9	57.0	59.7	60	60
	575	4.8	36.0	7.5	1.4	3.6	1.8	0.0	None	-	-	-	17.1	18.9	20	20
									E09	9.0	1	8.7	17.1	18.9	20	20
									E18	18.0	2	17.3	26.2	28.4	30	30
									E24	24.0	2	23.1	33.4	35.6	35	40
									E36	34.0	2	32.7	45.4	47.6	50	50
102 (8.5)	208	12.2	88.0	19.0	3.0	9.6	5.5	0.0	None	-	-	-	43.1	48.6	50	60
									E09	6.8	1	18.9	43.1	48.6	50	60
									E18	13.5	2	37.5	58.8	65.7	60	70
									E24	18.0	2	50.0	74.5	81.3	80	90
									E36	25.5	2	70.8	100.5	107.4	110	110
	230	12.2	88.0	19.0	3.0	9.6	5.5	0.0	None	-	-	-	43.1	48.6	50	60
									E09	9.0	1	21.7	43.1	48.6	50	60
									E18	18.0	2	43.3	66.1	73.0	70	80
									E24	24.0	2	57.7	84.2	91.0	90	100
									E36	34.0	2	81.8	114.2	121.1	125	125
	460	5.8	44.0	9.0	1.6	4.7	2.2	0.0	None	-	-	-	21.0	23.2	25	25
									E09	9.0	1	10.8	21.0	23.2	25	25
									E18	18.0	2	21.7	32.9	35.7	35	40
									E24	24.0	2	28.9	42.0	44.7	45	45
									E36	34.0	2	40.9	57.0	59.7	60	60
	575	4.4	36.0	5.5	1.4	3.6	1.8	0.0	None	-	-	-	16.2	18.0	20	20
									E09	9.0	1	8.7	16.2	18.0	20	20
									E18	18.0	2	17.3	26.2	28.4	30	30
									E24	24.0	2	23.1	33.4	35.6	35	40
									E36	34.0	2	32.7	45.4	47.6	50	50

ZJ078-150 Hi Static Motor - Without Powered Convenience Outlet (Continued)

Size (Tons)	Volt	Compressors (each)			OD Fan Motors (each)	Supply Blower Motor	Pwr Exh Motor	Pwr Conv Outlet	Electric Heat Option				MCA ¹ (Amps)	MCA ¹ w/Pwr Exh (Amps)	Max Fuse ² / Breaker ³ Size (Amps)	Max Fuse ² / Breaker ³ Size w/ Pwr Exh (Amps)
		RLA	LRA	MCC	FLA	FLA	FLA	FLA	Model	kW	Stages	Amps				
120 (10)	208	16.0	110.0	24.9	3.0	9.6	5.5	0.0	None	-	-	-	51.7	57.2	60	70
									E18	13.5	2	37.5	58.8	65.7	60	70
									E24	18.0	2	50.0	74.5	81.3	80	90
									E36	25.5	2	70.8	100.5	107.4	110	110
									E54	40.6	2	112.7	152.9	159.7	175	175
	230	16.0	110.0	24.9	3.0	9.6	5.5	0.0	None	-	-	-	51.7	57.2	60	70
									E18	18.0	2	43.3	66.1	73.0	70	80
									E24	24.0	2	57.7	84.2	91.0	90	100
									E36	34.0	2	81.8	114.2	121.1	125	125
									E54	54.0	2	129.9	141.9	148.8	175	175
	460	7.8	52.0	12.1	1.6	4.7	2.2	0.0	None	-	-	-	25.5	27.7	30	35
									E18	18.0	2	21.7	32.9	35.7	35	40
									E24	24.0	2	28.9	42.0	44.7	45	45
									E36	34.0	2	40.9	57.0	59.7	60	60
									E54	54.0	2	65.0	70.8	73.6	80	80
	575	5.7	38.9	8.9	1.4	3.6	1.8	0.0	None	-	-	-	19.1	20.9	20	25
									E18	18.0	2	17.3	26.2	28.4	30	30
									E24	24.0	2	23.1	33.4	35.6	35	40
									E36	34.0	2	32.7	45.4	47.6	50	50
									E54	54.0	2	52.0	56.5	58.7	70	70
150 (12.5)	208	23.1	160.0	36.0	2.1	14.0	5.5	0.0	None	-	-	-	74.4	79.9	90	100
									E18	13.5	2	37.5	74.4	79.9	90	100
									E24	18.0	2	50.0	80.0	86.8	90	100
									E36	25.5	2	70.8	106.0	112.9	110	125
									E54	40.6	2	112.7	158.4	165.2	175	175
	230	23.1	160.0	36.0	2.1	14.0	5.5	0.0	None	-	-	-	74.4	79.9	90	100
									E18	18.0	2	43.3	74.4	79.9	90	100
									E24	24.0	2	57.7	89.7	96.5	90	100
									E36	34.0	2	81.8	119.7	126.6	125	150
									E54	54.0	2	129.9	147.4	154.3	175	175
	460	12.2	87.0	19.0	1.3	6.6	2.2	0.0	None	-	-	-	39.1	41.3	50	50
									E18	18.0	2	21.7	39.1	41.3	50	50
									E24	24.0	2	28.9	44.3	47.1	50	50
									E36	34.0	2	40.9	59.4	62.1	60	70
									E54	54.0	2	65.0	73.2	76.0	80	90
	575	8.7	62.0	13.5	0.7	5.2	1.8	0.0	None	-	-	-	27.4	29.2	35	35
									E18	18.0	2	17.3	28.2	30.4	35	35
									E24	24.0	2	23.1	35.4	37.6	40	40
									E36	34.0	2	32.7	47.4	49.6	50	50
									E54	54.0	2	52.0	58.5	60.7	70	70

1. Minimum Circuit Ampacity.
2. Dual Element, Time Delay Type.
3. HACR type per NEC.

ZJ078-150 Standard Motor - With Powered Convenience Outlet

Size (Tons)	Volt	Compressors (each)			OD Fan Motors (each)	Supply Blower Motor	Pwr Exh Motor	Pwr Conv Outlet	Electric Heat Option				MCA ¹ (Amps)	MCA ¹ w/Pwr Exh (Amps)	Max Fuse ² / Breaker ³ Size (Amps)	Max Fuse ² / Breaker ³ Size w/ Pwr Exh (Amps)
		RLA	LRA	MCC	FLA	FLA	FLA	FLA	Model	kW	Stages	Amps				
078 (6.5)	208	9.3	68.0	14.5	2.1	5.2	5.5	10.0	None	-	-	-	40.5	46.0	50	50
									E09	6.8	1	18.9	42.6	49.5	50	50
									E18	13.5	2	37.5	65.8	72.7	70	80
									E24	18.0	2	50.0	81.5	88.3	90	90
									E36	25.5	2	70.8	107.5	114.4	110	125
	230	9.3	68.0	14.5	2.1	5.2	5.5	10.0	None	-	-	-	40.5	46.0	50	50
									E09	9.0	1	21.7	46.1	52.9	50	60
									E18	18.0	2	43.3	73.1	80.0	80	80
									E24	24.0	2	57.7	91.2	98.0	100	100
									E36	34.0	2	81.8	121.2	128.1	125	150
	460	4.9	34.0	7.6	1.3	2.6	2.2	5.0	None	-	-	-	21.2	23.4	25	25
									E09	9.0	1	10.8	23.0	25.8	25	30
									E18	18.0	2	21.7	36.6	39.3	40	40
									E24	24.0	2	28.9	45.6	48.3	50	50
									E36	34.0	2	40.9	60.6	63.4	70	70
	575	3.8	28.0	6.0	0.7	2.0	1.8	4.0	None	-	-	-	15.9	17.7	20	20
									E09	9.0	1	8.7	18.3	20.6	20	25
									E18	18.0	2	17.3	29.2	31.4	30	35
									E24	24.0	2	23.1	36.4	38.6	40	40
									E36	34.0	2	32.7	48.4	50.6	50	60
090 (7.5)	208	11.9	88.0	18.5	3.0	5.2	5.5	10.0	None	-	-	-	48.0	53.5	50	60
									E09	6.8	1	18.9	48.0	53.5	50	60
									E18	13.5	2	37.5	65.8	72.7	70	80
									E24	18.0	2	50.0	81.5	88.3	90	90
									E36	25.5	2	70.8	107.5	114.4	110	125
	230	11.9	88.0	18.5	3.0	5.2	5.5	10.0	None	-	-	-	48.0	53.5	50	60
									E09	9.0	1	21.7	48.0	53.5	50	60
									E18	18.0	2	43.3	73.1	80.0	80	80
									E24	24.0	2	57.7	91.2	98.0	100	100
									E36	34.0	2	81.8	121.2	128.1	125	150
	460	5.2	44.0	8.1	1.6	2.6	2.2	5.0	None	-	-	-	22.5	24.7	25	25
									E09	9.0	1	10.8	23.0	25.8	25	30
									E18	18.0	2	21.7	36.6	39.3	40	40
									E24	24.0	2	28.9	45.6	48.3	50	50
									E36	34.0	2	40.9	60.6	63.4	70	70
	575	4.8	36.0	7.5	1.4	2.0	1.8	4.0	None	-	-	-	19.5	21.3	20	25
									E09	9.0	1	8.7	19.5	21.3	20	25
									E18	18.0	2	17.3	29.2	31.4	30	35
									E24	24.0	2	23.1	36.4	38.6	40	40
									E36	34.0	2	32.7	48.4	50.6	50	60
102 (8.5)	208	12.2	88.0	19.0	3.0	6.8	5.5	10.0	None	-	-	-	50.3	55.8	60	60
									E09	6.8	1	18.9	50.3	55.8	60	60
									E18	13.5	2	37.5	67.8	74.7	70	80
									E24	18.0	2	50.0	83.5	90.3	90	100
									E36	25.5	2	70.8	109.5	116.4	110	125
	230	12.2	88.0	19.0	3.0	6.8	5.5	10.0	None	-	-	-	50.3	55.8	60	60
									E09	9.0	1	21.7	50.3	55.8	60	60
									E18	18.0	2	43.3	75.1	82.0	80	90
									E24	24.0	2	57.7	93.2	100.0	100	100
									E36	34.0	2	81.8	123.2	130.1	125	150
	460	5.8	44.0	9.0	1.6	3.4	2.2	5.0	None	-	-	-	24.7	26.9	30	30
									E09	9.0	1	10.8	24.7	26.9	30	30
									E18	18.0	2	21.7	37.6	40.3	40	45
									E24	24.0	2	28.9	46.6	49.3	50	50
									E36	34.0	2	40.9	61.6	64.4	70	70
	575	4.4	36.0	5.5	1.4	2.4	1.8	4.0	None	-	-	-	19.0	20.8	20	25
									E09	9.0	1	8.7	19.0	21.1	20	25
									E18	18.0	2	17.3	29.7	31.9	30	35
									E24	24.0	2	23.1	36.9	39.1	40	40
									E36	34.0	2	32.7	48.9	51.1	50	60

ZJ078-150 Standard Motor - With Powered Convenience Outlet (Continued)

Size (Tons)	Volt	Compressors (each)			OD Fan Motors (each)	Supply Blower Motor	Pwr Exh Motor	Pwr Conv Outlet	Electric Heat Option				MCA ¹ (Amps)	MCA ¹ w/Pwr Exh (Amps)	Max Fuse ² / Breaker ³ Size (Amps)	Max Fuse ² / Breaker ³ Size w/ Pwr Exh (Amps)
		RLA	LRA	MCC	FLA	FLA	FLA	FLA	Model	kW	Stages	Amps				
120 (10)	208	16.0	110.0	24.9	3.0	6.8	5.5	10.0	None	-	-	-	58.9	64.4	70	80
									E18	13.5	2	37.5	67.8	74.7	70	80
									E24	18.0	2	50.0	83.5	90.3	90	100
									E36	25.5	2	70.8	109.5	116.4	110	125
									E54	40.6	2	112.7	161.9	168.7	175	175
	230	16.0	110.0	24.9	3.0	6.8	5.5	10.0	None	-	-	-	58.9	64.4	70	80
									E18	18.0	2	43.3	75.1	82.0	80	90
									E24	24.0	2	57.7	93.2	100.0	100	100
									E36	34.0	2	81.8	123.2	130.1	125	150
									E54	54.0	2	129.9	150.9	157.8	175	175
	460	7.8	52.0	12.1	1.6	3.4	2.2	5.0	None	-	-	-	29.2	31.4	35	35
									E18	18.0	2	21.7	37.6	40.3	40	45
									E24	24.0	2	28.9	46.6	49.3	50	50
									E36	34.0	2	40.9	61.6	64.4	70	70
									E54	54.0	2	65.0	75.5	78.2	80	90
	575	5.7	38.9	8.9	1.4	2.4	1.8	4.0	None	-	-	-	21.9	23.7	25	25
									E18	18.0	2	17.3	29.7	31.9	30	35
									E24	24.0	2	23.1	36.9	39.1	40	40
									E36	34.0	2	32.7	48.9	51.1	50	60
									E54	54.0	2	52.0	60.0	62.2	70	70
150 (12.5)	208	23.1	160.0	36.0	2.1	9.6	5.5	10.0	None	-	-	-	80.0	85.5	100	100
									E18	13.5	2	37.5	80.0	85.5	100	100
									E24	18.0	2	50.0	87.0	93.8	100	100
									E36	25.5	2	70.8	113.0	119.9	125	125
									E54	40.6	2	112.7	165.4	172.2	175	175
	230	23.1	160.0	36.0	2.1	9.6	5.5	10.0	None	-	-	-	80.0	85.5	100	100
									E18	18.0	2	43.3	80.0	85.5	100	100
									E24	24.0	2	57.7	96.7	103.5	100	110
									E36	34.0	2	81.8	126.7	133.6	150	150
									E54	54.0	2	129.9	154.4	161.3	175	175
	460	12.2	87.0	19.0	1.3	4.7	2.2	5.0	None	-	-	-	42.2	44.4	50	50
									E18	18.0	2	21.7	42.2	44.4	50	50
									E24	24.0	2	28.9	48.2	51.0	50	60
									E36	34.0	2	40.9	63.2	66.0	70	70
									E54	54.0	2	65.0	77.1	79.8	90	90
	575	8.7	62.0	13.5	0.7	3.6	1.8	4.0	None	-	-	-	29.8	31.6	35	40
									E18	18.0	2	17.3	31.2	33.4	35	40
									E24	24.0	2	23.1	38.4	40.6	40	45
									E36	34.0	2	32.7	50.4	52.6	60	60
									E54	54.0	2	52.0	61.5	63.7	70	70

1. Minimum Circuit Ampacity.
2. Dual Element, Time Delay Type.
3. HACR type per NEC.

ZJ078-150 Hi Static Motor - With Powered Convenience Outlet

Size (Tons)	Volt	Compressors (each)			OD Fan Motors (each)	Supply Blower Motor	Pwr Exh Motor	Pwr Conv Outlet	Electric Heat Option				MCA ¹ (Amps)	MCA ¹ w/Pwr Exh (Amps)	Max Fuse ² / Breaker ³ Size (Amps)	Max Fuse ² / Breaker ³ Size w/ Pwr Exh (Amps)
		RLA	LRA	MCC	FLA	FLA	FLA	FLA	Model	kW	Stages	Amps				
078 (6.5)	208	9.3	68.0	14.5	2.1	6.8	5.5	10.0	None	-	-	-	42.1	47.6	50	50
									E09	6.8	1	18.9	44.6	51.5	50	60
									E18	13.5	2	37.5	67.8	74.7	70	80
									E24	18.0	2	50.0	83.5	90.3	90	100
	230	9.3	68.0	14.5	2.1	6.8	5.5	10.0	None	-	-	-	42.1	47.6	50	50
									E09	9.0	1	21.7	48.1	54.9	50	60
									E18	18.0	2	43.3	75.1	82.0	80	90
									E24	24.0	2	57.7	93.2	100.0	100	100
	460	4.9	34.0	7.6	1.3	3.4	2.2	5.0	None	-	-	-	22.0	24.2	25	25
									E09	9.0	1	10.8	24.0	26.8	25	30
									E18	18.0	2	21.7	37.6	40.3	40	45
									E24	24.0	2	28.9	46.6	49.3	50	50
575	3.8	28.0	6.0	0.7	2.4	1.8	4.0	None	-	-	-	16.3	18.1	20	20	
								E09	9.0	1	8.7	18.8	21.1	20	25	
								E18	18.0	2	17.3	29.7	31.9	30	35	
								E24	24.0	2	23.1	36.9	39.1	40	40	
090 (7.5)	208	11.9	88.0	18.5	3.0	9.6	5.5	10.0	None	-	-	-	52.4	57.9	60	60
									E09	6.8	1	18.9	52.4	57.9	60	60
									E18	13.5	2	37.5	71.3	78.2	80	80
									E24	18.0	2	50.0	87.0	93.8	90	100
	230	11.9	88.0	18.5	3.0	9.6	5.5	10.0	None	-	-	-	52.4	57.9	60	60
									E09	9.0	1	21.7	52.4	58.4	60	60
									E18	18.0	2	43.3	78.6	85.5	80	90
									E24	24.0	2	57.7	96.7	103.5	100	110
	460	5.2	44.0	8.1	1.6	4.7	2.2	5.0	None	-	-	-	24.6	26.8	25	30
									E09	9.0	1	10.8	25.7	28.4	30	30
									E18	18.0	2	21.7	39.2	41.9	40	45
									E24	24.0	2	28.9	48.2	51.0	50	60
575	4.8	36.0	7.5	1.4	3.6	1.8	4.0	None	-	-	-	21.1	22.9	25	25	
								E09	9.0	1	8.7	21.1	22.9	25	25	
								E18	18.0	2	17.3	31.2	33.4	35	35	
								E24	24.0	2	23.1	38.4	40.6	40	45	
102 (8.5)	208	12.2	88.0	19.0	3.0	9.6	5.5	10.0	None	-	-	-	53.1	58.6	60	70
									E09	6.8	1	18.9	53.1	58.6	60	70
									E18	13.5	2	37.5	71.3	78.2	80	80
									E24	18.0	2	50.0	87.0	93.8	90	100
	230	12.2	88.0	19.0	3.0	9.6	5.5	10.0	None	-	-	-	53.1	58.6	60	70
									E09	9.0	1	21.7	53.1	58.6	60	70
									E18	18.0	2	43.3	78.6	85.5	80	90
									E24	24.0	2	57.7	96.7	103.5	100	110
	460	5.8	44.0	9.0	1.6	4.7	2.2	5.0	None	-	-	-	26.0	28.2	30	30
									E09	9.0	1	10.8	26.0	28.4	30	30
									E18	18.0	2	21.7	39.2	41.9	40	45
									E24	24.0	2	28.9	48.2	51.0	50	60
575	4.4	36.0	5.5	1.4	3.6	1.8	4.0	None	-	-	-	20.2	22.0	25	25	
								E09	9.0	1	8.7	20.3	22.6	25	25	
								E18	18.0	2	17.3	31.2	33.4	35	35	
								E24	24.0	2	23.1	38.4	40.6	40	45	
575	4.4	36.0	5.5	1.4	3.6	1.8	4.0	E36	34.0	2	32.7	50.4	52.6	60	60	

ZJ078-150 Hi Static Motor - With Powered Convenience Outlet (Continued)

Size (Tons)	Volt	Compressors (each)			OD Fan Motors (each)	Supply Blower Motor	Pwr Exh Motor	Pwr Conv Outlet	Electric Heat Option				MCA ¹ (Amps)	MCA ¹ w/Pwr Exh (Amps)	Max Fuse ² / Breaker ³ Size (Amps)	Max Fuse ² / Breaker ³ Size w/ Pwr Exh (Amps)
		RLA	LRA	MCC	FLA	FLA	FLA	FLA	Model	kW	Stages	Amps				
120 (10)	208	16.0	110.0	24.9	3.0	9.6	5.5	10.0	None	-	-	-	61.7	67.2	70	80
									E18	13.5	2	37.5	71.3	78.2	80	80
									E24	18.0	2	50.0	87.0	93.8	90	100
									E36	25.5	2	70.8	113.0	119.9	125	125
									E54	40.6	2	112.7	165.4	172.2	175	175
	230	16.0	110.0	24.9	3.0	9.6	5.5	10.0	None	-	-	-	61.7	67.2	70	80
									E18	18.0	2	43.3	78.6	85.5	80	90
									E24	24.0	2	57.7	96.7	103.5	100	110
									E36	34.0	2	81.8	126.7	133.6	150	150
									E54	54.0	2	129.9	154.4	161.3	175	175
	460	7.8	52.0	12.1	1.6	4.7	2.2	5.0	None	-	-	-	30.5	32.7	35	40
									E18	18.0	2	21.7	39.2	41.9	40	45
									E24	24.0	2	28.9	48.2	51.0	50	60
									E36	34.0	2	40.9	63.2	66.0	70	70
									E54	54.0	2	65.0	77.1	79.8	90	90
	575	5.7	38.9	8.9	1.4	3.6	1.8	4.0	None	-	-	-	23.1	24.9	25	30
									E18	18.0	2	17.3	31.2	33.4	35	35
									E24	24.0	2	23.1	38.4	40.6	40	45
									E36	34.0	2	32.7	50.4	52.6	60	60
									E54	54.0	2	52.0	61.5	63.7	70	70
150 (12.5)	208	23.1	160.0	36.0	2.1	14.0	5.5	10.0	None	-	-	-	84.4	89.9	100	110
									E18	13.5	2	37.5	84.4	89.9	100	110
									E24	18.0	2	50.0	92.5	99.3	100	110
									E36	25.5	2	70.8	118.5	125.4	125	150
									E54	40.6	2	112.7	170.9	177.7	175	200
	230	23.1	160.0	36.0	2.1	14.0	5.5	10.0	None	-	-	-	84.4	89.9	100	110
									E18	18.0	2	43.3	84.4	91.0	100	110
									E24	24.0	2	57.7	102.2	109.0	110	110
									E36	34.0	2	81.8	132.2	139.1	150	150
									E54	54.0	2	129.9	159.9	166.8	175	175
	460	12.2	87.0	19.0	1.3	6.6	2.2	5.0	None	-	-	-	44.1	46.3	50	50
									E18	18.0	2	21.7	44.1	46.3	50	50
									E24	24.0	2	28.9	50.6	53.3	60	60
									E36	34.0	2	40.9	65.6	68.4	70	70
									E54	54.0	2	65.0	79.5	82.2	90	90
	575	8.7	62.0	13.5	0.7	5.2	1.8	4.0	None	-	-	-	31.4	33.2	40	40
									E18	18.0	2	17.3	33.2	35.4	40	40
									E24	24.0	2	23.1	40.4	42.6	45	45
									E36	34.0	2	32.7	52.4	54.6	60	60
									E54	54.0	2	52.0	63.5	65.7	70	70

1. Minimum Circuit Ampacity.
2. Dual Element, Time Delay Type.
3. HACR type per NEC.

Table 9: Physical Data
ZJ078-150 Physical Data

Component	Models									
	ZJ078		ZJ090		ZJ102		ZJ120		ZJ150	
Nominal Tonnage	6.5		7.5		8.5		10		12.5	
AHRI COOLING PERFORMANCE										
Gross Capacity @ AHRI A point (Btu)	80000		93000		106000		124000		154000	
AHRI net capacity (Btu)	77000		90000		102000		120000		150000	
EER	12.2 ¹ /12.0 ²		12.2		12.2 ¹ /12.0 ²		12.0		12.0	
SEER	-		-		-		-		-	
IEER	13.5		13		12.8		12.8		13	
IPLV	14.9		14.18		13.6		13.4		14.1	
CFM	2600		2500		3400		3400		3500	
System power (KW)	6.40		7.38		8.30		9.80		12.50	
Refrigerant type	R-410A		R-410A		R-410A		R-410A		R-410A	
Refrigerant charge (lb-oz)										
System 1	5-10		7-12		8-8		7-14		10-8	
System 2	5-12		7-10		8-12		7-14		9-12	
AHRI HEATING PERFORMANCE										
Heating model	N12	N18	N12	N18	N12	N18	N18	N24	N18	N24
Heat input (K Btu)	120	180	120	180	120	180	180	240	180	240
Heat output (K Btu)	96	144	96	144	96	144	144	192	144	192
AFUE %	-	-	-	-	-	-	-	-	-	-
Steady state efficiency (%)	80	80	80	80	80	80	80	80	80	80
No. burners	4	6	4	6	4	6	6	8	6	8
No. stages	2 ³	2 ³	2 ³	2 ³	2 ³	2 ³	2 ³	2 ³	2 ³	2 ³
Temperature Rise Range (°F)	20-50	35-65	15-45	30-60	10-40	25-55	20-50	35-65	10-40	25-55
Gas Limit Setting (°F)	165	165	165	165	215	195	195	160	195	160
Gas piping connection (in.)	3/4	3/4	3/4	3/4	3/4	3/4	3/4	3/4	3/4	3/4
DIMENSIONS (inches)										
Length	89		89		89		89		119-1/2	
Width	59		59		59		59		59	
Height	50-3/4		50-3/4		50-3/4		50-3/4		50-3/4	
OPERATING WT. (lbs.)										
1030 1050 1060 1070 1280										
COMPRESSORS										
Type	Recip		Recip		Recip		Scroll		Scroll	
Quantity	2		2		2		2		2	
Unit Capacity Steps (%)	50 / 100		50 / 100		50 / 100		50 / 100		50 / 100	
CONDENSER COIL DATA										
Face area (Sq. Ft.)	29.0		23.8		29.0		29.0		47.5	
Rows	1		1		1		1		1	
Fins per inch	23		23		23		23		23	
Tube diameter (in./MM)	.71/18		1/25		1/25		1/25		.71/18	
Circuitry Type	2-pass Microchannel		2-pass Microchannel		2-pass Microchannel		2-pass Microchannel		2-pass Microchannel	
EVAPORATOR COIL DATA										
Face area (Sq. Ft.)	13.2		13.2		13.2		13.2		13.2	
Rows	3		4		4		4		4	
Fins per inch	15		15		15		15		15	
Tube diameter	0.375		0.375		0.375		0.375		0.375	
Circuitry Type	Intertwined		Intertwined		Intertwined		Intertwined		Intertwined	
Refrigerant control	TXV		TXV		TXV		TXV		TXV	

ZJ078-150 Physical Data (Continued)

Component	Models									
	ZJ078		ZJ090		ZJ102		ZJ120		ZJ150	
Nominal Tonnage	6.5		7.5		8.5		10		12.5	
CONDENSER FAN DATA										
Quantity of fans	2		2		2		2		4	
Fan diameter (Inch)	24		24		24		24		24	
Type	Prop		Prop		Prop		Prop		Prop	
Drive type	Direct		Direct		Direct		Direct		Direct	
Quantity of motors	2		2		2		2		4	
Motor HP each	1/3		3/4		3/4		3/4		1/3	
No. speeds	1		1		1		1		1	
RPM	850		1110		1110		1110		850	
Total CFM	7400		9000		9000		9400		14000	
BELT DRIVE EVAP FAN DATA										
Quantity	1		1		1		1		1	
Fan Size (Inch)	15 x 15		15 x 15		15 x 15		15 x 15		15 x 15	
Type	Centrifugal		Centrifugal		Centrifugal		Centrifugal		Centrifugal	
Motor Sheave	1VL40	1VM50	1VL40	1VM50	1VM50	1VM50	1VM50	1VM50	1VM50	1VP56
Blower Sheave	AK74	AK74	AK69	AK69	AK89	AK74	AK84	AK74	AK74	BK77
Belt	A53	A54	A53	A54	A56	A54	A56	A54	A54	BX55
Motor HP each	1-1/2	2	1-1/2	3	2	3	2	3	3	5
RPM	1725	1725	1725	1725	1725	1725	1725	1725	1725	1725
Frame size	56	56	56	56	56	56	56	56	56	184T
FILTERS										
Quantity - Size	4 - (24 x 20 x 2) ^{4,5}		4 - (24 x 20 x 2) ^{4,5}		4 - (24 x 20 x 2) ^{4,5}		4 - (24 x 20 x 2) ^{4,5}		4 - (24 x 20 x 2) ^{4,5}	
	4 - (24 x 20 x 4) ⁶		4 - (24 x 20 x 4) ⁶		4 - (24 x 20 x 4) ⁶		4 - (24 x 20 x 4) ⁶		4 - (24 x 20 x 4) ⁶	

1. Cooling Only Unit
2. Cooling Unit with Gas or Electric Heat
3. 1st Stage 60% of 2nd Stage.
4. 2 In. Throwaway, Standard, MERV (Minimum Efficiency Reporting Value) 3
5. 2 In. Pleated, Optional, MERV 7.
6. 4 In. Pleated, Optional, MERV 14.

Optional Electric Heat

The factory-installed heaters are wired for single point power supply. Power supply need only be brought into the single point terminal block.

These CSA approved heaters are located within the central compartment of the unit with the heater elements extending in to the supply air chamber.

Fuses are supplied, where required, by the factory. Some kW sizes require fuses and others do not. refer to Table 10 for minimum CFM limitations and to Table 8 for electrical data.

Table 10: Electric Heat Minimum Supply Air

Size (Tons)	Model	Voltage	Minimum Supply Air (CFM)				
			Heater kW				
			9	18	24	36	54
078 (6.5)	ZJ	208/230-3-60	1950	1950	1950	1950	-
		460-3-60	1950	1950	1950	1950	-
		600-3-60	1950	1950	1950	1950	-
090 (7.5)	ZJ	208/230-3-60	2250	2250	2250	2250	-
		460-3-60	2250	2250	2250	2250	-
		600-3-60	2250	2250	2250	2250	-
102 (8.5)	ZJ	208/230-3-60	2550	2550	2550	2550	-
		460-3-60	2550	2550	2550	2550	-
		600-3-60	2550	2550	2550	2550	-
120 (10)	ZJ	208/230-3-60	-	3000	3000	3000	3500
		460-3-60	-	3000	3000	3000	3000
		600-3-60	-	3000	3000	3000	3500
150 (12.5)	ZJ	208/230-3-60	-	3750	3750	3750	4000
		460-3-60	-	3750	3750	3750	3750
		600-3-60	-	3750	3750	3750	3750

Optional Gas Heat

These gas-fired heaters have aluminized-steel or optional stainless steel, tubular heat exchangers with spark ignition.

NOTE: On VAV units, individual VAV boxes must be fully open in heating mode to insure airflow falls within specified Temperature Rise range.

Gas Piping

Proper sizing of gas piping depends on the cubic feet per hour of gas flow required, specific gravity of the gas and the length of run. "National Fuel Gas Code" Z223.1 (in U.S.A.) or the current Gas Installation Codes CSA-B149.1 (in Canada) should be followed in all cases unless superseded by local codes or gas utility requirements. Refer to the Pipe Sizing Table 11. The heating value of the gas may differ with locality. The value should be checked with the local gas utility.

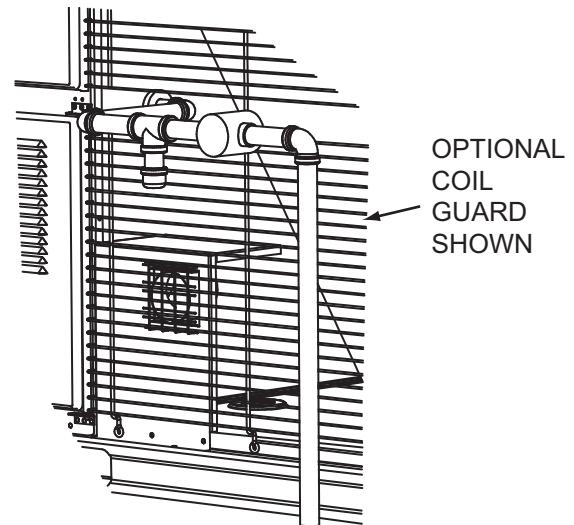

Figure 25: Side Entry Gas Piping

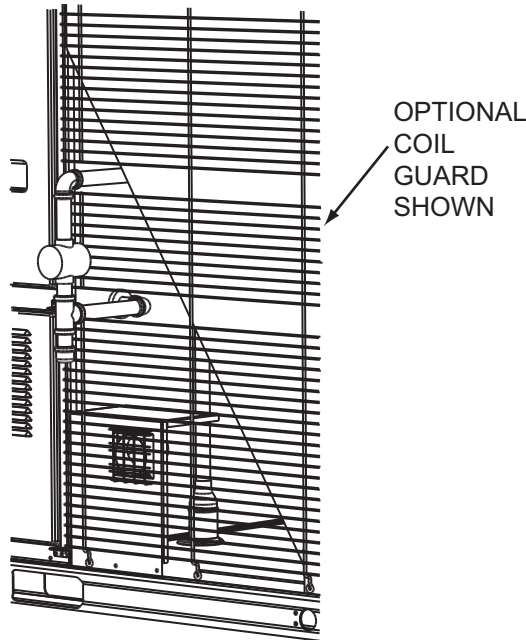

Figure 26: Bottom Entry Gas Piping

Table 11: Gas Pipe Sizing - Capacity of Pipe

Length of Pipe (ft.)	Nominal Iron Pipe Size		
	3/4 in.	1 in.	1-1/4 in.
10	278	520	1050
20	190	350	730
30	152	285	590
40	130	245	500
50	115	215	440
60	105	195	400
70	96	180	370
80	90	170	350
90	84	160	320
100	79	150	305

NOTE: Maximum capacity of pipe in cubic feet of gas per hour based upon a pressure drop of 0.3 inch W.C. and 0.6 specific gravity gas.

NOTE: There may be a local gas utility requirement specifying a minimum diameter for gas piping. All units require a 3/4 inch pipe connection at the entrance fitting. Line should not be sized smaller than the entrance fitting size.

Table 12: Gas Heat Minimum Supply Air

Size (Tons)	Model	Heat Size	Supply Air (CFM)			
			Cooling		Heating	
			Min	Max	Min	Max
078 (6.5)	ZJ	N12	1950	3250	1950	3250
		N18	1950	3250	1950	3250
090 (7.5)	ZJ	N12	2250	3750	2250	3750
		N18	2250	3750	2250	3750
102 (8.5)	ZJ	N12	2550	4250	2550	4250
		N18	2550	4250	2550	4250
120 (10)	ZJ	N18	3000	5000	3000	5000
		N24	3000	5000	3000	5000
150 (12.5)	ZJ	N18	3750	6250	3750	6250
		N24	3750	6250	3750	6250

Gas Connection

The gas supply line can be routed within the space and roof curb, exiting through the unit's basepan. Refer to Figures 8 and 9 for the gas piping inlet location. Typical supply piping arrangements are shown in Figures 25 and 26. All pipe nipples, fittings, and the gas cock are field supplied or may be purchased in UP accessory kit #1GP0405.

Gas piping recommendations:

1. A drip leg and a ground joint union must be installed in the gas piping.
2. Where required by local codes, a manual shut-off valve must be installed outside of the unit.
3. Use wrought iron or steel pipe for all gas lines. Pipe dope should be applied sparingly to male threads only.

WARNING

Natural gas may contain some propane. Propane is an excellent solvent and will quickly dissolve white lead and most standard commercial compounds. A special pipe dope must be used when assembling wrought iron or steel pipe. Shellac based compounds such as Gaskolac or Stalastic, and compounds such as Rectorseal #5, Clydes's or John Crane may be used.

4. All piping should be cleaned of dirt and scale by hammering on the outside of the pipe and blowing out loose particles. Before initial start-up, be sure that all gas lines external to the unit have been purged of air.
5. The gas supply should be a separate line and installed in accordance with all safety codes as prescribed under "Limitations".

6. A 1/8-inch NPT plugged tapping, accessible for test gage connection, must be installed immediately upstream of the gas supply connection to the unit.
7. After the gas connections have been completed, open the main shut-off valve admitting normal gas pressure to the mains. Check all joints for leaks with soap solution or other material suitable for the purpose. **NEVER USE A FLAME.**

WARNING

FIRE OR EXPLOSION HAZARD

Failure to follow the safety warning exactly could result in serious injury, death or property damage.

Never test for gas leaks with an open flame. use a commercially available soap solution made specifically for the detection of leaks to check all connections. A fire or explosion may result causing property damage, personal injury or loss of life.

CAUTION

The furnace and its individual shut-off valve must be disconnected from the gas supply piping system during any pressure testing at pressures in excess of 1/2 PSIG.

Pressures greater than 1/2 PSIG will cause gas valve damage resulting in a hazardous condition. If it is subjected to a pressure greater than 1/2 PSIG, the gas valve must be replaced.

The furnace must be isolated from the gas supply piping system by closing its individual manual shut-off valve during any pressure testing of the gas supply piping system at test pressures equal to or less than 1/2 PSIG.

WARNING

Threaded joints should be coated with a sealing compound that is resistant to the action of liquefied petroleum gases. **Do not use Teflon tape.**

Lp Units, Tanks And Piping

All gas heat units are shipped from the factory equipped for natural gas use only. The unit may be converted in the field for use with LP gas with accessory kit model number 1NP0442.

All LP gas equipment must conform to the safety standards of the National Fire Protection Association.

For satisfactory operation, LP gas pressure must be 10.5 inch W.C. at the unit under full load. Maintaining proper gas pressure depends on three main factors:

1. The vaporization rate which depends on the temperature of the liquid and the "wetted surface" area of the container(s).

2. The proper pressure regulation. (Two-stage regulation is recommended).
3. The pressure drop in the lines between regulators and between the second stage regulator and the appliance. Pipe size required will depend on the length of the pipe run and the total load of all appliances.

Complete information regarding tank sizing for vaporization, recommended regulator settings, and pipe sizing is available from most regulator manufacturers and LP gas suppliers.

WARNING

LP gas is an excellent solvent and will quickly dissolve white lead and most standard commercial compounds. A special pipe dope must be used when assembling wrought iron or steel pipe for LP. Shellac base compounds such as Gaskolac or Stalastic, and compounds such as Rectorseal #5, Clyde's, or John Crane may be used.

Check all connections for leaks when piping is completed using a soap solution. **NEVER USE A FLAME.**

WARNING

FIRE OR EXPLOSION HAZARD

Failure to follow the safety warning exactly could result in serious injury, death or property damage.

Never test for gas leaks with an open flame. use a commercially available soap solution made specifically for the detection of leaks to check all connections. A fire or explosion may result causing property damage, personal injury or loss of life.

Vent And Combustion Air

Venting slots in the heating compartment access panel remove the need for a combustion air hood. The gas heat flue exhaust is routed through factory installed exhaust piping with screen. If necessary, a flue exhaust extension may be installed at the point of installation.

Options/Accessories

Electric Heat

Electric heaters are available as factory-installed options or field-installed accessories. Refer to electric heat instructions for installation. These heaters mount in the heat compartment with the heating elements extending into the supply air chamber. All electric heaters are fused and intended for use with single point power supply.

Smoke Detectors

WARNING

The use of duct smoke detectors have specific limitations as established by the National Fire Protection Association. Duct smoke detectors are; NOT a substitute for an open area smoke detector, NOT a substitute for early warning detection, and NOT a replacement for a building's regular fire detection system. Refer to NFPA Code 72 and Standard 90A for additional information.

The factory-installed smoke detector will shut down operation of the unit by interrupting power to the UCB when smoke is detected within its mounting compartment. The smoke detector option is available for both supply and/or return air configurations. Be aware that the supply air configuration has the sensor component mounted in the blower section, with its control module mounted in the return air compartment.

WARNING

Factory-installed smoke detectors may be subjected to extreme temperatures during "off" times due to outside air infiltration. These smoke detectors have an operational limit of -4°F to 158°F. Smoke detectors installed in areas that could be outside this range will have to be relocated to prevent false alarms.

WARNING

To assure adequate airflow reaches the smoke detector's sensor, make sure that the holes of the sampling tube face into the air stream, and that the far-end of the sampling tube is sealed with the plastic end cap.

In addition, the unit's supply airflow must be adjusted to provide a pressure differential across the smoke detector's sampling and exhaust ports of at least 0.01 inches of water and no more than 1.11 inches of water, as measured by a manometer.

The detector must be tested and maintained on a regular basis according to NFPA 72 requirements and cleaned at least once a year. For specific troubleshooting and maintenance procedures, please refer to the smoke detector's installation instructions which accompanies the unit.

Motorized Outdoor Damper

The Motorized Outdoor Damper can be a factory installed option or a field installed accessory. If factory installed, refer to the instructions included with the outdoor air hood to complete the assembly. Field installed Motorized Outdoor Damper accessories include complete instructions for installation.

Economizer

The Economizer can be a factory installed option or a field installed accessory. If factory installed, refer to the instructions included with the outdoor air hood to complete the assembly. Field installed Economizer accessories include complete instructions for installation.

There are two Economizer options:

1. Down Flow, End Return Horizontal applications which include Fresh Air Hood, Exhaust Hood with Barometric Relief.
2. Horizontal Flow application (Field Installed Kit Only) that requires the purchase of a barometric relief hood.
3. With the Down Flow, End Return Horizontal application it is required to save the two Side Panels for the economizer hood tops (See Figure 20).

Power Exhaust

The Power Exhaust can be a factory installed option or a field installed accessory. If factory installed, refer to the instructions included with the outdoor air hood to complete the assembly. Field installed Power Exhaust accessories include complete instructions for installation.

The Power Exhaust factory installed option is for Down Flow application only.

There are two field installed Power Exhaust accessories:

1. Down Flow application.
2. Horizontal Flow application that requires the purchase of a barometric relief hood.

Rain Hood

All of the hood components, including the filters, the gasketing and the hardware for assembling, are packaged and located between the condenser coil section and the main unit cabinet, if the unit has factory installed options. If field installed accessories are being installed all parts necessary for the installation comes in the accessory.

Optional Variable Air Volume (VAV)

A variable air volume (VAV) option using a variable frequency drive (VFD) is available for applications requiring a constant supply-duct static pressure. A differential pressure transducer is used to monitor supply duct static pressure and return a speed reference signal to the VFD to control the output of the indoor blower motor.

Duct Static Pressure Transducer

A 0-5" WC pressure transducer, located in the control box compartment, is used to sense static (gauge) pressure in the supply air duct and convert this pressure measurement to a proportional 0-5 VDC electrical output. Pressure-transmitting plastic tubing (1/4" diameter) must be field supplied and installed from the transducer to both the ductwork and to the atmosphere. Connect the tubing from the 'HIGH' pressure tap of

the transducer to a static pressure tap (field supplied) in the supply duct located at a point where constant pressure is expected. To prevent an unstable signal due to air turbulence, there should be no obstructions, turns or VAV terminal boxes up- or down-stream of the sensing tube location for at least a distance of 6-10 times the duct diameter. Tubing must also be run between the 'LOW' pressure tap of the transducer and atmospheric pressure (outside of the unit).

CAUTION

Do not run plastic tubing in the supply or return air ducts as air movement could cause erroneous pressure measurements. If the tubing penetrates through the bottom of the unit be sure openings are sealed to prevent air and water leakage.

Factory-installed VFD

The factory-installed VFD is mounted in the blower access compartment. The drive comes wired from the factory to include both 3-phase power and control connections (run permit signal, speed reference signal & fault signal). All required drive parameters are pre-programmed at the factory, except in the case of 208-volt applications, in which the parameter that defines motor nameplate voltage must be changed to a value of 208.00 and the parameter that defines motor-rated current must be changed to the appropriate value appearing on the motor's nameplate. Refer to the enclosed drive material or access the UPGnet Commercial Product Catalog website for instructions on changing parameter settings.

For units also equipped with gas/electric heat, a terminal block located in the unit's control box and connected to the VAV board's "VAV BOX" terminal, must be field wired to the building's VAV boxes to ensure fully open dampers during heating operation.

Manual Bypass

An optional, factory-installed manual bypass switch available with factory-installed VFD can be found in the Blower Motor Access compartment and has the following three positions:

- **DRIVE** - routes power through the VFD for modulating control of the indoor blower motor.
- **LINE (or BYPASS)** - routes power directly to the motor which provides full-speed motor operation and complete electrical isolation of the drive.
- **TEST** - routes power to the VFD but not to the motor to allow for drive programming and/or diagnostics.

If a drive failure occurs, the unit does not automatically switch to bypass mode. The LINE/DRIVE/TEST switch must be manually switched to the LINE (BYPASS) position. If there is a call for the fan, the indoor blower motor will run at full-speed while in the bypass mode.

CAUTION

If the unit is operated with the manual bypass switch in the LINE (BYPASS) position and there are VAV boxes present in the duct system, then boxes must be driven to the full-open position using a customer-supplied power source to prevent over-pressurizing and possible damage to the ductwork.

WARNING

Before beginning any service, disconnect all power to the drive. Be aware that high voltages are present in the drive even after power has been disconnected. Capacitors within the drive must be allowed to discharge before beginning service.

Bas-ready VFD

Factory-installed VFD is also available with 'BAS-Ready' models. Terminal blocks are provided in the control box (in place of the VAV control board) for field wiring of a customer-installed BAS to receive 24 VAC power and to connect to the following control signals:

- a duct static pressure transducer input signal (0-5 VDC)
- an economizer actuator input signal (2-10 VDC)
- an economizer actuator output signal (2-10 VDC)
- a VFD speed reference output signal (2-10 VDC)

The use of shielded cable is recommended for the above control wiring connections.

NOTE: Factory-installed VFD is not available with factory-installed BAS options due to space limitations in the control box.

A solid-state, lock-out relay (LR) and 100 microfarad, 50 VDC capacitor must be field-supplied and installed to provide a means to transmit a potential fault signal back to the BAS controller. The specific relay part number required will depend upon the need for either AC-output or DC-output. See price pages for further details.

Once the appropriate relay and capacitor are obtained, install the capacitor across LR terminals '3' & '4' and make the following wiring connections:

- LR '1' to BAS controller
- LR '2' to BAS controller
- LR '3' to UCB 'X'
- LR '4' to UCB 'C'

'VFD-ready' For Customer-installation

Units configured as 'VFD-ready' provide provisions for a customer-installed drive. The physical dimensions of VFDs can

vary greatly among manufacturers, horsepower ratings and voltage requirements. Keep in mind that drive manufacturers also require various minimum clearances to allow for adequate internal cooling of the drive during operation.

The unit comes with a mounting bracket installed in the Blower Access compartment which may accommodate other vendor's drives depending on their size. In order to utilize the unit's mounting bracket, the maximum recommended drive dimensions are limited to approximately 9" H x 5" W x 7.5" D.

If the drive will not fit in the allotted space, then it will need to be mounted elsewhere; either within the building on a perpendicular wall which is not subjected to excessive temperature, vibration, humidity, dust, corrosive gas, explosive gas, etc., or within an appropriate enclosure rated for outside installation to safeguard against moisture, dust and excessive heat.

The power leads to the drive (L1, L2, L3) and from the motor (T1, T2, T3) have been temporarily spliced together with wire nuts. After removing the wire nuts, connect the wires to the field-installed VFD per the VFD wiring diagram (See Figure 27). The VFD should also be grounded per the manufacturer's specifications.

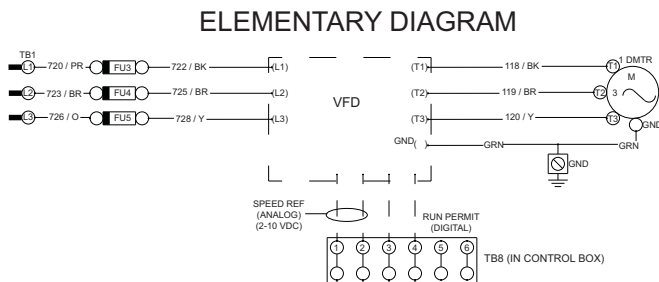

Figure 27: Simplified VFD Wiring

CAUTION

Do not connect AC power to the T1, T2, T3 drive terminals to prevent damage to the VFD.

CAUTION

The fuses (FU3, FU4, FU5) supplied with the unit are sized according to the electrical load of the blower motor, but may not provide adequate protection to the customer-installed drive, depending upon its specifications. Once a drive has been selected and installed, refer to the drive manufacturer's recommendations for proper fuse sizing.

A terminal block located in the control box is provided for field connection of the VFD speed reference signal (2-10 VDC) and to the normally-open, run-permit auxiliary contact. The use of shielded cable is recommended for the above control wiring

connections. For VFD-ready units also equipped with gas/ electric heat, a terminal block located in the unit's control box and connected to the VAV board's "VAV BOX" terminal, must be field wired to the building's VAV boxes to ensure fully open dampers during heating operation.

Optional Hot Gas Bypass (HGBP)

To allow for low cooling load operation, a direct-acting, pressure-modulating bypass control valve installed on the system #1 discharge line is used to divert high temperature, high pressure refrigerant around the TXV in order to maintain a desired minimum evaporator pressure.

The opening pressure of the bypass valve is adjustable between 95 and 115 psig with a factory-setting of 105 psig. HGBP is standard on all units with VAV and optional with CV units.

Economizer Sequences

Several functions can drive the economizer, including: minimum position, free cooling, economizer loading, and minimum outdoor air supply.

Economizer Minimum Position

The economizer minimum position is set during occupied mode when outside air is not suitable for free cooling. The position of the damper is set proportionally between the "Economizer Minimum Position" and the Economizer Minimum Position Low Speed Fan" set points, in relationship to the VFD output percentage. On a constant volume single speed supply fan system both set-points should be set to the same value.

Free Cooling

Four types of free cooling options are available: dry bulb changeover, single enthalpy, dual enthalpy changeover, and Auto.

Dry Bulb Changeover

For dry bulb economizer operation, the outside air is suitable for free cooling if the outside air temperature is 1°F below the Economizer OAT Enable Setpoint **and** 1°F below the Return Air Temperature.

Free cooling is no longer available if the outside air temperature rises above **either** the Economizer OAT Enable setpoint **or** the return air temperature.

Single Enthalpy Changeover

For single enthalpy economizer operation, the outside air is suitable for free cooling if the outside air enthalpy is at least 1 BTU/lb below the Economizer Outside Air Enthalpy Setpoint **and** the outside air temperature is no greater than the RAT plus 9°F.

If the outside air temperature rises above the RAT plus 10°F, free cooling is no longer available. The outside air temperature must drop to no greater than RAT plus 9°F to enter free cooling again.

Free cooling is no longer available if the outside air enthalpy rises above the Economizer Outside Air Enthalpy Setpoint.

Dual Enthalpy Changeover

For dual enthalpy economizer operation, the outside air enthalpy must be lower than the return air enthalpy by 1 btu/lb AND the outside air temperature is no greater than the RAT plus 9°F.

Auto

The control determines the type of free cooling changeover based on which sensors are present and reliable. Conditions include:

- Return and outside air dry bulb = dry bulb changeover
- Return and outside air dry bulb and outside air humidity = single enthalpy
- Return and outside air dry bulb and return and outside air humidity = dual enthalpy
- If either the return or outside air dry bulb sensors are unreliable, free cooling is not available

Free Cooling Operation

When the control determines that the outside air is suitable, the first stage of cooling will always be free cooling.

Thermostat

In free cooling, with a thermostat input to Y1, the dampers modulate to control the supply air temperature to the Economizer Setpoint +/- 1°F (default 55°F).

If the thermostat provides an input to Y2 **and** the parameter Compressors Off in Free Cooling is turned OFF a compressor output energizes. The economizer dampers continue to modulate to control the supply air temperature to the Economizer Setpoint.

If the supply air temperature cannot be maintained within 5°F of the economizer setpoint, the first stage compressor (C1) will be turned on. Second stage compressor (C2) will be added as needed to keep the supply air temperature within the 5°F of the economizer setpoint.

Sensor

In free cooling, with a demand from the zone/return sensor for the first stage of cooling, the dampers modulate to control the supply air temperature to the Economizer Setpoint +/- 1°F.

If the economizer output is at 100% **and** the SAT is greater than the Economizer setpoint + 1°F, the control starts a 12-minute timer to energize a compressor output.

If at any time the economizer output drops below 100% the timer stops and resets when the economizer output returns to 100%.

Once a compressor output is turned ON, the economizer dampers continue to modulate to control the supply air temperature to the Economizer Setpoint.

At no time will a compressor output be turned ON if the economizer output is less than 100%, even if the differential between zone (or return) temperature and the current cooling setpoint is great enough to demand more than one stage of cooling.

If the economizer output goes to minimum position **and** the SAT is less than Economizer Setpoint -1°F, the control starts a 12-minute timer to de-energize a compressor output.

If at any time the economizer output goes above the minimum position the timer stops and resets when the economizer output returns to minimum position.

If the demand for cooling from the space/return is satisfied, the economizer output will modulate to minimum position and the compressor outputs will be de-energized as long as their minimum run timers have expired.

Power Exhaust

Setpoints

a. Economizer Enable	ON
b. Power Exhaust Enable	ON
c. Modulating Power Exhaust	OFF
d. Exhaust VFD Installed	OFF
e. Building Pressure Sensor Enabled	OFF
f. Econo Damper Position For Exh Fan	ON Percent
g. Econo Damper Position For Exh Fan	OFF Percent

Inputs

No inputs are present for non-modulating power exhaust.

Outputs

- a. 2-10 VDC from ECON on Economizer Expansion module
- b. 24 VAC from EX-FAN to energize exhaust fan on Economizer Expansion module

Operation

Operation details include:

- a. Compares economizer output to the Economizer Damper Position For Exhaust Fan On and OFF.
- b. Energizes exhaust fan when economizer output is above Economizer Damper Position For Exhaust Fan On.
- c. De-energizes exhaust fan when economizer output is below the Economizer Damper Position for Exhaust Fan OFF

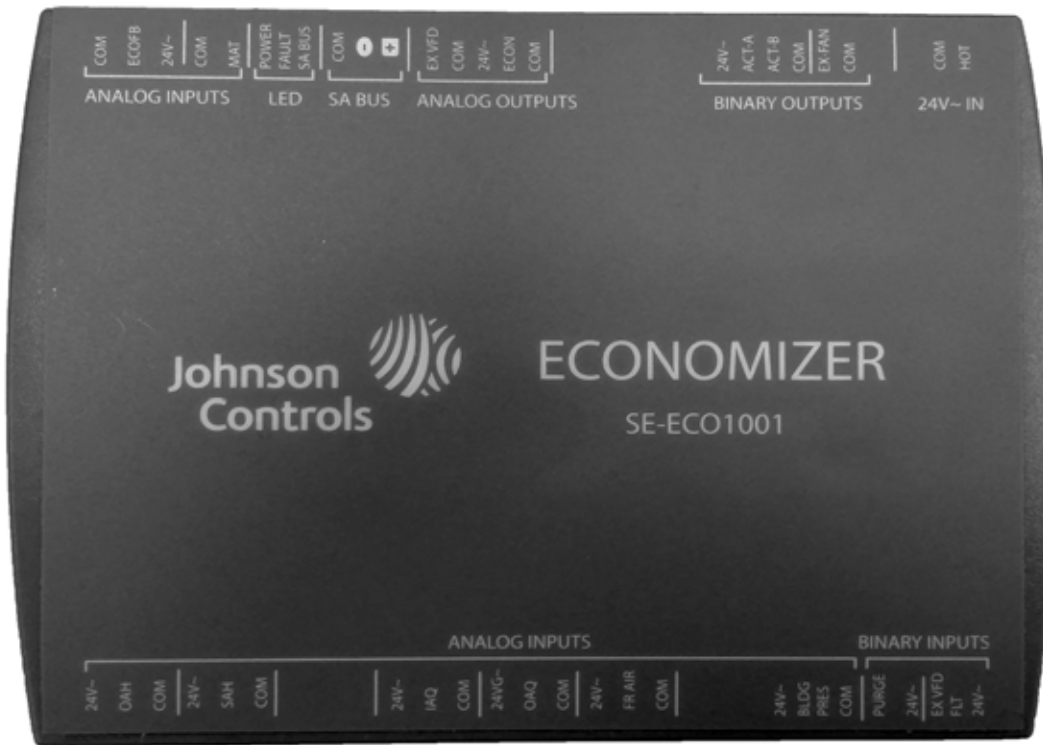

Figure 28: SE-ECO1001-0 Economizer Controller

Table 13: Simplicity SE Economizer Board Details

Board Label	Cover Label	Description	Function & Comments
Directional orientation: viewed with the center text of the cover label upright			
ANALOG INPUTS Terminal at left on upper edge of economizer board			
C	COM	24 VAC common/0-10 VDC negative for economizer actuator position feedback	Connects through circuit trace to 24V~ IN pin COM
IN2	ECOFB	0-10 VDC positive input from Economizer actuator position Feedback	EconDampPos parameter reports input status (0-100%). Used to meet Cali. Title 24 requirements for economizer actuator position feedback
R	24V~	24 VAC hot supplied for economizer actuator position feedback	Connects through circuit trace to 24V~ IN pin HOT
C	COM	Mixed Air Temperature sensor input from 10KΩ	MAT parameter reports input status (°F/°C), 3.65 VDC reading MAT (+) to COM (-) with open circuit. Read-only use in current control revision.
IN1	MAT	@ 77°F, Type III negative temperature coefficient thermistor	
LEDs at left on upper edge of economizer board			
POWER	POWER	Green UCB power indicator	Lit indicates 24 VAC is present at 24V~ IN COM and HOT pins
FAULT	FAULT	Red networking error and firmware error indicator	1/10th second on/off flashing indicates a networking error (polarity, addressing, etc.) or a firmware error (likely correctable with re-loading from USB flash drive)
SA BUS	SA BUS	Green UCB SA bus communication transmission indicator	Lit/flickering indicates UCB-to-economizer board SA bus communication is currently active, off indicates the economizer board is awaiting SA bus communication
SA BUS Pin connections at left on upper edge of economizer board			
C	COM	Common for SA BUS power and communication circuits	EconCtrlr parameter reports UCB-to-economizer board SA bus communication status. Negative of the SA BUS communication circuit to the UCB. Through the unit wiring harness, may continue on to the 4-stage board and/or fault detection & diagnostics board

Table 13: Simplicity SE Economizer Board Details (Continued)

Board Label	Cover Label	Description	Function & Comments
-	-	Communication for SA BUS devices	EconCtrlr parameter reports UCB-to-economizer board SA BUS communication status. Positive of the VDC (typically, a fluctuating 1.5 to 3.5 volts reading to C; at least 0.25 volts lower than +) SA BUS communication circuit to the UCB. Through the unit wiring harness, may continue on to the 4-stage board and/or fault detection & diagnostics board
+	+	Communication for SA BUS devices	EconCtrlr parameter reports UCB-to-economizer board SA BUS communication status. Positive of the VDC (typically, a fluctuating 1.5 to 3.5 volts reading to C; at least 0.25 volts higher than -) SA BUS communication circuit to the UCB. Through the unit wiring harness, may continue on to the 4-stage board and/or fault detection & diagnostics board
ANALOG OUTPUTS Pin at center on upper edge of economizer board			
J4	EX VFD	2-10 VDC positive output for the modulating power Exhaust fan Variable Frequency Drive/ discharge damper modulating power exhaust actuator	ExFanVFD parameter reports output status (0-100%) when ExFType selection is Variable Frequency Fan; EAD-O parameter reports output status (0-100%) when ExFType selection is Modulating Damper. Used to ramp the power exhaust fan VFD/ position the discharge damper actuator.
	COM	24 VAC common/0-10 VDC negative for the power exhaust variable frequency drive/ discharge damper modulating power exhaust actuator	Connects through circuit trace to 24V~ IN pin COM
	24V~	24 VAC hot supplied for the discharge damper modulating power exhaust actuator and economizer actuator	Connects through circuit trace to 24V~ IN pin HOT
	ECON	2-10 VDC output for the Economizer actuator	Econ parameter reports output status (0-100%). Used to position the economizer actuator for minimum position, free cooling, demand ventilation, cooling economizer loading and purge functions
	COM	24 VAC common/0-10 VDC negative for economizer actuator	Connects through circuit trace to 24V~ IN pin COM
BINARY OUTPUTS Pin at right on upper edge of economizer board			
J3	24V~	24 VAC hot supplied for an incremental (floating control) economizer actuator	Connects through circuit trace to 24V~ IN pin HOT
	ACT-A	24 VAC hot outputs to position an incremental (floating control) economizer actuator	Unused in current control revision
	ACT-B	24 VAC return	Unused in current control revision
	COM	24 VAC common for an incremental (floating control) economizer actuator	Connects through circuit trace to 24V~ IN pin COM
	EX-FAN	24 VAC hot output to energize power exhaust fan contactor coil/VFD enable relay coil	ExFan parameter reports output status (Off-On) when ExFType selection is Non-Modulating, Modulating Damper or Variable Frequency Fan. Used to turn on/enable the power exhaust fan motor.
	COM	24 VAC common/0-10 VDC negative for economizer actuator	Connects through circuit trace to 24V~ IN pin COM
24V~ IN Pin connections at right on upper edge of economizer board			
C	COM	24 VAC transformer Common referenced to cabinet ground	24 VAC common connection to power the economizer board. Connects through circuit traces to C/COM terminals and pins distributed on the economizer board.

Table 13: Simplicity SE Economizer Board Details (Continued)

Board Label	Cover Label	Description	Function & Comments
R	HOT	24 VAC transformer HOT	24 VAC hot connection to power the economizer board. Connects through circuit traces to R/24V~ terminals and pins distributed on the economizer board.
ANALOG INPUTS Terminal on lower edge of economizer board			
R	24V~	24 VAC hot supplied for the outdoor air humidity sensor	Connects through circuit trace to 24V~ IN pin HOT
IN3	OAH	0-10 VDC positive input from the Outdoor Air Humidity sensor	OAH parameter reports input status (0-100%H). Used in outdoor air enthalpy calculation for dual enthalpy economizer free cooling changeover.
C	COM	24 VAC common/0-10 VDC negative for the outdoor air humidity sensor	Connects through circuit trace to 24V~ IN pin COM
R	24V~	24 VAC hot supplied for the supply air humidity sensor	Connects through circuit trace to 24V~ IN pin HOT
IN4	SAH	0-10 VDC positive input from the Supply Air Humidity sensor	SAH parameter reports input status (0-100%H). Unused in current control revision.
C	COM	24 VAC common/0-10 VDC negative for the supply air humidity sensor	Connects through circuit trace to 24V~ IN pin COM
R	24V~	24 VAC hot supplied for the indoor air quality sensor	Connects through circuit trace to 24V~ IN pin HOT
IN5	IAQ	0-10 VDC positive input from the Indoor Air Quality sensor	IAQRange parameter sets the CO2 parts per million measured by the indoor air quality sensor when it outputs 10 VDC; IAQ parameter reports input status (0-5000ppm). Used for demand ventilation functions if the NetIAQ parameter indicates ?Unrel.
C	COM	24 VAC common/0-10 VDC negative for the indoor air quality sensor	Connects through circuit trace to 24V~ IN pin COM
R	24V~	24 VAC hot supplied for the outdoor air quality sensor	Connects through circuit trace to 24V~ IN pin HOT
IN6	OAQ	0-10 VDC positive input from the Outdoor Air Quality sensor	OAQRange parameter sets the CO2 parts per million measured by the outdoor air quality sensor when it outputs 10 VDC; OAQ parameter reports input status (0-5000ppm). Used for demand ventilation function when DVent-Mode selection is Diff between IAQ and OAQ and the NetOAQ parameter indicates ?Unrel.
C	COM	24 VAC common/0-10 VDC negative for the outdoor air quality sensor	Connects through circuit trace to 24V~ IN pin COM
R	24V~	24 VAC hot supplied for the air monitoring station sensor	Connects through circuit trace to 24V~ IN pin HOT
IN7	FR AIR	0-10 VDC positive input from the air monitoring station sensor	MOA-Range parameter sets the cubic feet per minute/liters per second measured by the air monitoring station sensor when it outputs 10 VDC; Fr Air parameter reports input status (0-50000CFM/23595lps). Used for economizer minimum position reset in speed-controlled indoor blower applications.
C	COM	24 VAC common/0-10 VDC negative for the air monitoring station sensor	Connects through circuit trace to 24V~ IN pin COM
R	24V~	24 VAC hot supplied for the building pressure sensor	Connects through circuit trace to 24V~ IN pin HOT
IN8	BLDG PRES	0-5 VDC positive input from the Building Pressure sensor	BldgPres parameter reports input status (-.250-.250"/w/-.062-.062kPa). Used for modulating power exhaust functions when ExFType selection is Modulating Damper or Variable Frequency Fan.

Table 13: Simplicity SE Economizer Board Details (Continued)

Board Label	Cover Label	Description	Function & Comments
C	COM	24 VAC common/0-5 VDC negative for the building pressure sensor	Connects through circuit trace to 24V~ IN pin COM
BINARY INPUTS at right on lower edge of economizer board			
IN9	PURGE	24 VAC hot input from the PURGE dry contact	Purge parameter reports input status (False with 0 VAC input-True with 24 VAC input). When Purge status is True, heating and cooling operation is prevented, the indoor blower and power exhaust fan operate, the economizer actuator is positioned to 100%.
	24V~	24 VAC hot supplied for the purge dry contact	Connects through circuit trace to 24V~ IN pin HOT
IN10	EX VFD FLT	24 VAC hot input from the power Exhaust Variable Frequency Drive Fault contact	ExFanVFDFIt parameter reports input status (Normal with 0 VAC input-Alarm with 24 VAC input) when ExFType selection is Variable Frequency Fan. When ExFanVFDFIt status is Alarm, EX-FAN fan output is prevented.
	24V~	24 VAC hot supplied for the power exhaust variable frequency drive fault contact	Connects through circuit trace to 24V~ IN pin HOT

Indoor Air Quality - IAQ

Indoor Air Quality (indoor sensor input): The Indoor Air Quality sensor is connected to the economizer board through the IAQ analog input terminal and the associated COM and 24V~ inputs on the economizer board. Terminal IAQ accepts a 0 to +10 Vdc signal with respect to the (IAQ) terminal. When the signal is below its set point, the actuator is allowed to modulate normally in accordance with the enthalpy and mixed air sensor inputs. When the IAQ signal exceeds its set point setting, and there is no call for free cooling, the actuator is proportionately modulated from the 0 to 10 Vdc signal, with 0 Vdc corresponding to full closed and 10 Vdc corresponding to full open. When there is no call for free cooling, the damper position is limited by the IAQ Max damper position setting. When the signal exceeds its set point (Demand Control Ventilation Set Point) setting and there is a call for free cooling, the actuator modulates from the minimum position to the full open position based on the highest call from either the mixed air sensor input or the IAQ voltage input.

- Optional CO2 Space Sensor Kit Part #2AQ04700524
- Optional CO2 Sensor Kit Part #2AQ04700624

Phasing

Predator® units are properly phased at the factory. Check for proper compressor rotation. If the blower or compressors rotate in the wrong direction at start-up, the electrical connection to the unit is misphased. Change the phasing of the **Field Line Connection at the factory or field supplied disconnect** to obtain proper rotation. (Scroll compressors operate in only one

direction. If the scroll is drawing low amperage, has similar suction and discharge pressures, or producing a high noise level, the scroll is misphased.)

⚠ CAUTION

Scroll compressors require proper rotation to operate correctly. Units are properly phased at the factory. Do not change the internal wiring to make the blower condenser fans, or compressor rotate correctly.

Blower Rotation

Check for proper supply air blower rotation. If the blower is rotating backwards, the line voltage at the unit point of power connection is misphased (See 'PHASING').

Table 14: Supply Air Limitations

Unit Size (Ton)	Minimum	Maximum
078 (6.5)	1950	3250
090 (7.5)	2250	3750
102 (8.5)	2550	4250
120 (10)	3000	5000
150 (12.5)	3750	6250

Belt Tension

The tension on the belt should be adjusted as shown in Figure 29.

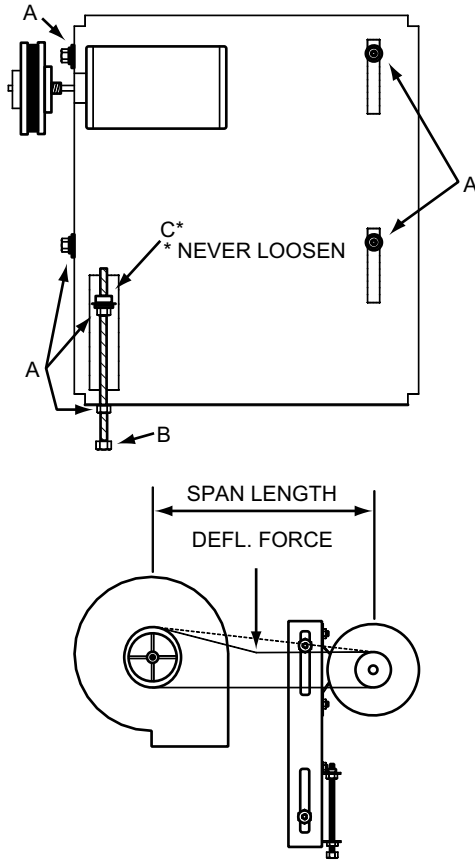

Figure 29: Belt Adjustment

CAUTION

Procedure for adjusting belt tension:

1. Loosen six nuts (top and bottom) A.
2. Adjust by turning (B).
3. Never loosen nuts (C).
4. Use belt tension checker to apply a perpendicular force to one belt at the midpoint of the span as shown. Deflection distance of 4mm (5/32") is obtained.

To determine the deflection distance from normal position, use a straight edge from sheave to sheave as reference line. The recommended deflection force is as follows:

Tension new belts at the max. deflection force recommended for the belt section. Check the belt tension at least two times during the first 24 hours of operation. Any retensioning should fall between the min. and max. deflection force values.

5. After adjusting re-tighten nuts (A).

CFM Static Pressure and Power-Altitude and Temperature Corrections

The information below should be used to assist in application of product when being applied at altitudes at or exceeding 1000 feet above sea level.

The air flow rates listed in the standard blower performance tables are based on standard air at sea level. As the altitude or temperature increases, the density of air decreases. In order to use the indoor blower tables for high altitude applications, certain corrections are necessary.

A centrifugal fan is a "constant volume" device. This means that, if the rpm remains constant, the CFM delivered is the same regardless of the density of the air. However, since the air at high altitude is less dense, less static pressure will be generated and less power will be required than a similar application at sea level. Air density correction factors are shown in Table 15 and Figure 30.

Table 15: Altitude/Temperature Correction Factors

Air Temp.	Altitude (Ft.)										
	0	1000	2000	3000	4000	5000	6000	7000	8000	9000	10000
40	1.060	1.022	0.986	0.950	0.916	0.882	0.849	0.818	0.788	0.758	0.729
50	1.039	1.002	0.966	0.931	0.898	0.864	0.832	0.802	0.772	0.743	0.715
60	1.019	0.982	0.948	0.913	0.880	0.848	0.816	0.787	0.757	0.729	0.701
70	1.000	0.964	0.930	0.896	0.864	0.832	0.801	0.772	0.743	0.715	0.688
80	0.982	0.947	0.913	0.880	0.848	0.817	0.787	0.758	0.730	0.702	0.676
90	0.964	0.929	0.897	0.864	0.833	0.802	0.772	0.744	0.716	0.689	0.663
100	0.946	0.912	0.880	0.848	0.817	0.787	0.758	0.730	0.703	0.676	0.651

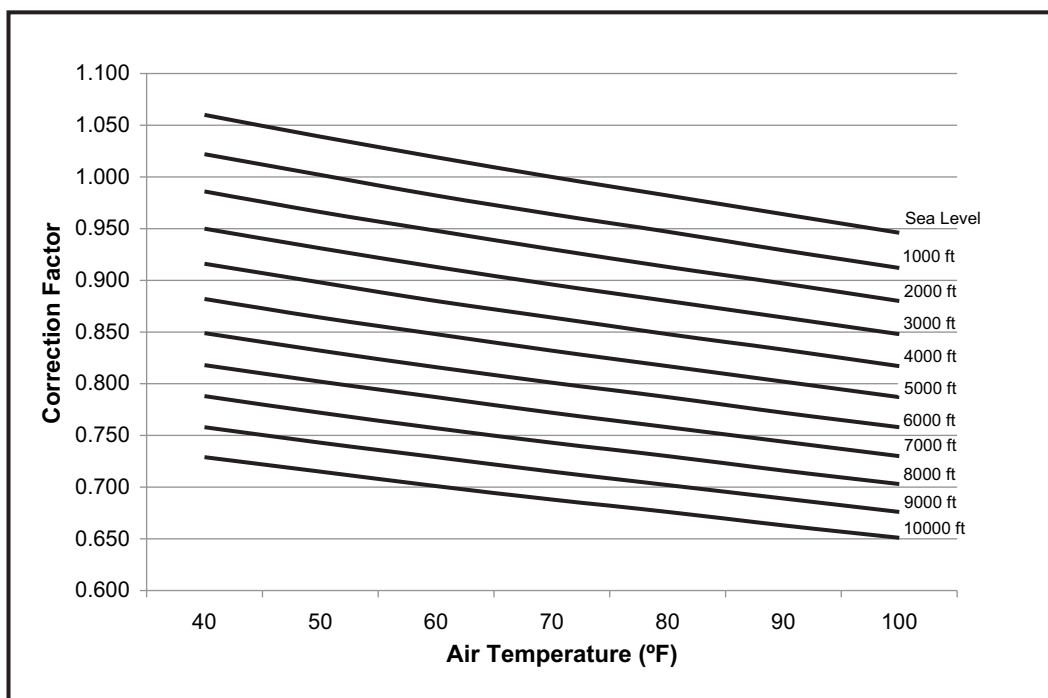
**Figure 30: Altitude/Temperature Correction Factors**

The examples below will assist in determining the airflow performance of the product at altitude.

Example 1: What are the corrected CFM, static pressure, and BHP at an elevation of 5,000 ft. if the blower performance data is 6,000 CFM, 1.5 IWC and 4.0 BHP?

Solution: At an elevation of 5,000 ft. the indoor blower will still deliver 6,000 CFM if the rpm is unchanged. However, Table 14 must be used to determine the static pressure and BHP. Since no temperature data is given, we will assume an air temperature of 70°F. Table 16 shows the correction factor to be 0.832.

$$\text{Corrected static pressure} = 1.5 \times 0.832 = 1.248 \text{ IWC}$$

$$\text{Corrected BHP} = 4.0 \times 0.832 = 3.328$$

Example 2: A system, located at 5,000 feet of elevation, is to deliver 6,000 CFM at a static pressure of 1.5". Use the unit

blower tables to select the blower speed and the BHP requirement.

Solution: As in the example above, no temperature information is given so 70°F is assumed.

The 1.5" static pressure given is at an elevation of 5,000 ft. The first step is to convert this static pressure to equivalent sea level conditions.

$$\text{Sea level static pressure} = 1.5 / .832 = 1.80"$$

Enter the blower table at 6000 sCFM and static pressure of 1.8". The rpm listed will be the same rpm needed at 5,000 ft.

Suppose that the corresponding BHP listed in the table is 3.2. This value must be corrected for elevation.

$$\text{BHP at 5,000 ft.} = 3.2 \times .832 = 2.66$$

Drive Selection

1. Determine side or bottom supply duct Application.
2. Determine desired airflow.
3. Calculate or measure the amount of external static pressure.
4. Using the operating point determined from steps 1, 2 & 3, locate this point on the appropriate supply air blower performance table. (Linear interpolation may be necessary.)
5. Noting the RPM and BHP from step 4, locate the appropriate motor and, or drive on the RPM selection table.
6. Review the BHP compared to the motor options available. Select the appropriate motor and, or drive.
7. Review the RPM range for the motor options available. Select the appropriate drive if multiple drives are available for the chosen motor.
8. Determine turns open to obtain the desired operation point.

Example

1. 2600 CFM
2. 1.6 iwg
3. Using the supply air blower performance table below, the following data point was located: 1268 RPM & 1.95 BHP.
4. Using the RPM selection table below, Size X and Model Y is found.
5. 1.95 BHP exceeds the maximum continuous BHP rating of the 1.5 HP motor. The 2 HP motor is required.
6. 1268 RPM is within the range of the 2 HP drives.
7. Using the 2 HP motor and drive, .5 turns open will achieve 1268 RPM.

Example Supply Air Blower Performance

Air Flow (CFM)	Available External Static Pressure - IWG																					
	0.2		0.4		0.6		0.8		1.0		1.2		1.4		1.6		1.8		2.0			
	RPM	BHP	RPM	BHP	RPM	BHP	RPM	BHP	RPM	BHP	RPM	BHP	RPM	BHP	RPM	BHP	RPM	BHP	RPM	BHP		
	1.5 HP & Field Supplied Drive														Standard 1.5 HP & Drive				Alternate 2 HP & Drive			
2200	804	0.50	866	0.71	925	0.90	982	1.06	1038	1.21	1092	1.35	1147	1.48	1203	1.61	1259	1.73	1317	1.87		
2400	835	0.66	897	0.87	956	1.06	1013	1.22	1069	1.37	1124	1.51	1178	1.64	1234	1.77	1290	1.90	1348	2.03		
2600	869	0.84	931	1.05	990	1.24	1047	1.40	1103	1.55	1158	1.69	1212	1.82	1268	1.95	1324	2.07	1382	2.21		
2800	906	1.03	968	1.25	1027	1.43	1084	1.60	1139	1.75	1194	1.89	1249	2.02	1304	2.14	1361	2.27	-	-		

Table X: RPM Selection

Size (Tons)	Model	HP	Max BHP	Motor Sheave	Blower Sheave	6 Turns Open	5 Turns Open	4 Turns Open	3 Turns Open	2 Turns Open	1 Turn Open	Fully Closed
X	Y	1.5	1.73	1VM50	AK74	N/A	897	945	991	1035	1079	1126
		2	2.30	1VM50	AK64	N/A	1039	1094	1150	1207	1256	1308

Airflow Performance

Table 16: Airflow Performance - Side Duct Application
ZJ078 (6.5 Ton) Side Duct

Air Flow (CFM)	Available External Static Pressure - IWG ¹																			
	0.2		0.4		0.6		0.8		1.0		1.2		1.4		1.6		1.8		2.0	
	RPM	BHP	RPM	BHP	RPM	BHP	RPM	BHP	RPM	BHP	RPM	BHP	RPM	BHP	RPM	BHP	RPM	BHP	RPM	BHP
	FS ⁴				Standard 1.5 HP & Drive						Hi Static 2 HP & Drive									
1800	514	0.15	586	0.33	657	0.52	727	0.71	794	0.89	857	1.07	917	1.23	972	1.38	1021	1.50	1064	1.59
2000	529	0.23	601	0.41	672	0.60	741	0.79	808	0.97	872	1.15	931	1.31	986	1.46	1036	1.58	1079	1.67
2200	544	0.33	616	0.51	687	0.69	756	0.88	823	1.07	886	1.24	946	1.41	1001	1.55	1051	1.67	1094	1.77
2400	559	0.43	631	0.61	702	0.80	771	0.98	838	1.17	902	1.35	961	1.51	1016	1.65	1066	1.78	1109	1.87
2600	574	0.54	646	0.72	717	0.91	787	1.10	853	1.28	917	1.46	977	1.62	1032	1.77	1081	1.89	1124	1.98
2800	590	0.67	662	0.85	733	1.03	802	1.22	869	1.41	933	1.59	993	1.75	1047	1.89	1097	2.02	1140	2.11
3000	607	0.80	679	0.98	750	1.17	819	1.36	886	1.54	949	1.72	1009	1.88	1064	2.03	1113	2.15	1157	2.24
3200	624	0.95	695	1.13	766	1.31	836	1.50	903	1.69	966	1.86	1026	2.03	1081	2.17	1130	2.29	-	-
3400	641	1.10	713	1.28	784	1.47	853	1.66	920	1.84	984	2.02	1043	2.18	1098	2.33	-	-	-	-
													FS ⁴							

1. Blower performance includes gas heat exchangers and 2" filters. See STATIC RESISTANCE table for additional applications.
2. See RPM SELECTION table to determine desired motor sheave setting and to determine the maximum continuous BHP.
3. kW = BHP x 0.932.
4. Field Supplied Drive.

ZJ090 (7.5 Ton) Side Duct

Air Flow (CFM)	Available External Static Pressure - IWG ¹																			
	0.2		0.4		0.6		0.8		1.0		1.2		1.4		1.6		1.8		2.0	
	RPM	BHP	RPM	BHP	RPM	BHP	RPM	BHP	RPM	BHP	RPM	BHP	RPM	BHP	RPM	BHP	RPM	BHP	RPM	BHP
	FS ⁴				Standard 1.5 HP & Drive						Hi Static 3 HP & Drive									
2000	-	-	656	0.24	711	0.48	768	0.73	826	0.96	886	1.19	945	1.41	1003	1.61	1058	1.79	1110	1.95
2200	619	0.07	670	0.32	724	0.57	781	0.81	840	1.04	899	1.27	959	1.49	1016	1.69	1072	1.87	1124	2.04
2400	631	0.16	682	0.41	736	0.66	793	0.90	852	1.14	911	1.36	970	1.58	1028	1.78	1084	1.97	1136	2.13
2600	642	0.27	692	0.52	747	0.76	804	1.01	862	1.24	922	1.47	981	1.69	1039	1.89	1094	2.07	1146	2.24
2800	652	0.39	703	0.64	757	0.88	814	1.13	873	1.36	932	1.59	992	1.81	1049	2.01	1105	2.19	1157	2.36
3000	663	0.53	714	0.77	768	1.02	825	1.26	884	1.50	943	1.73	1003	1.94	1060	2.14	1116	2.33	1168	2.49
3200	675	0.68	726	0.92	780	1.17	837	1.41	896	1.65	955	1.88	1014	2.09	1072	2.29	1128	2.48	1180	2.64
3400	688	0.84	739	1.09	793	1.34	850	1.58	909	1.82	968	2.04	1027	2.26	1085	2.46	1141	2.65	1193	2.81
3600	703	1.03	753	1.28	807	1.52	864	1.76	923	2.00	983	2.23	1042	2.44	1100	2.64	1155	2.83	-	-
3800	718	1.23	769	1.47	823	1.72	880	1.96	939	2.20	998	2.43	1058	2.64	1115	2.84	1171	3.03	-	-

1. Blower performance includes gas heat exchangers and 2" filters. See STATIC RESISTANCE table for additional applications.
2. See RPM SELECTION table to determine desired motor sheave setting and to determine the maximum continuous BHP.
3. kW = BHP x 0.932.
4. Field Supplied Drive.

ZJ102 (8.5 Ton) Side Duct

Air Flow (CFM)	Available External Static Pressure - IWG ¹																			
	0.2		0.4		0.6		0.8		1.0		1.2		1.4		1.6		1.8		2.0	
	RPM	BHP	RPM	BHP	RPM	BHP	RPM	BHP	RPM	BHP	RPM	BHP	RPM	BHP	RPM	BHP	RPM	BHP	RPM	BHP
	Field Supplied Drive				Standard 2 HP & Drive						Hi Static 3 HP & Drive									
2200	654	0.32	706	0.53	755	0.73	803	0.92	849	1.10	893	1.27	937	1.44	979	1.62	1020	1.79	1061	1.96
2400	664	0.43	716	0.64	765	0.83	813	1.02	859	1.20	904	1.38	947	1.55	989	1.72	1030	1.89	1071	2.07
2600	675	0.53	726	0.74	776	0.94	824	1.12	870	1.30	914	1.48	957	1.65	1000	1.82	1041	1.99	1082	2.17
2800	686	0.63	738	0.84	787	1.04	835	1.23	881	1.41	925	1.58	969	1.76	1011	1.93	1052	2.10	1093	2.27
3000	699	0.75	750	0.96	800	1.16	847	1.34	893	1.52	938	1.70	981	1.87	1024	2.04	1065	2.21	1106	2.39
3200	713	0.88	764	1.09	814	1.28	861	1.47	907	1.65	952	1.83	995	2.00	1037	2.17	1079	2.34	1119	2.52
3400	728	1.02	779	1.23	829	1.43	877	1.61	923	1.79	967	1.97	1010	2.14	1053	2.31	1094	2.48	1135	2.66
3600	745	1.18	796	1.39	846	1.59	893	1.77	939	1.95	984	2.13	1027	2.30	1069	2.47	1111	2.64	1152	2.82
3800	763	1.36	815	1.57	864	1.76	912	1.95	958	2.13	1002	2.31	1046	2.48	1088	2.65	1129	2.82	1170	3.00
4000	783	1.55	835	1.76	884	1.96	932	2.15	978	2.33	1022	2.50	1066	2.67	1108	2.84	1149	3.02	1190	3.19
4200	805	1.77	856	1.98	906	2.17	953	2.36	999	2.54	1044	2.72	1087	2.89	1129	3.06	1171	3.23	1211	3.41
													3 HP & Field Supplied Drive							

1. Blower performance includes gas heat exchangers and 2" filters. See STATIC RESISTANCE table for additional applications.
2. See RPM SELECTION table to determine desired motor sheave setting and to determine the maximum continuous BHP.
3. kW = BHP x 0.932.

ZJ120 (10 Ton) Side Duct

Air Flow (CFM)	Available External Static Pressure - IWG ¹																			
	0.2		0.4		0.6		0.8		1.0		1.2		1.4		1.6		1.8		2.0	
	RPM	BHP	RPM	BHP	RPM	BHP	RPM	BHP	RPM	BHP	RPM	BHP	RPM	BHP	RPM	BHP	RPM	BHP	RPM	BHP
	Field Supplied Drive				Standard 2 HP & Drive								Hi Static 3 HP & Drive							
2600	675	0.53	726	0.74	776	0.94	824	1.12	870	1.30	914	1.48	957	1.65	1000	1.82	1041	1.99	1082	2.17
2800	686	0.63	738	0.84	787	1.04	835	1.23	881	1.41	925	1.58	969	1.76	1011	1.93	1052	2.10	1093	2.27
3000	699	0.75	750	0.96	800	1.16	847	1.34	893	1.52	938	1.70	981	1.87	1024	2.04	1065	2.21	1106	2.39
3200	713	0.88	764	1.09	814	1.28	861	1.47	907	1.65	952	1.83	995	2.00	1037	2.17	1079	2.34	1119	2.52
3400	728	1.02	779	1.23	829	1.43	877	1.61	923	1.79	967	1.97	1010	2.14	1053	2.31	1094	2.48	1135	2.66
3600	745	1.18	796	1.39	846	1.59	893	1.77	939	1.95	984	2.13	1027	2.30	1069	2.47	1111	2.64	1152	2.82
3800	763	1.36	815	1.57	864	1.76	912	1.95	958	2.13	1002	2.31	1046	2.48	1088	2.65	1129	2.82	1170	3.00
4000	783	1.55	835	1.76	884	1.96	932	2.15	978	2.33	1022	2.50	1066	2.67	1108	2.84	1149	3.02	1190	3.19
4200	805	1.77	856	1.98	906	2.17	953	2.36	999	2.54	1044	2.72	1087	2.89	1129	3.06	1171	3.23	1211	3.41
4400	828	2.00	879	2.21	929	2.41	976	2.59	1022	2.77	1067	2.95	1110	3.12	1152	3.29	-	-	-	-
4600	852	2.25	904	2.46	953	2.66	1001	2.85	1047	3.03	1092	3.20	1135	3.37	-	-	-	-	-	-
4800	879	2.52	930	2.73	980	2.93	1027	3.12	1073	3.30	-	-	-	-	-	-	-	-	-	-
5000	906	2.81	958	3.02	1007	3.22	1055	3.41	-	-	-	-	-	-	-	-	-	-	-	-
													3 HP & Field Supplied Drive							

1. Blower performance includes gas heat exchangers and 2" filters. See STATIC RESISTANCE table for additional applications.
2. See RPM SELECTION table to determine desired motor sheave setting and to determine the maximum continuous BHP.
3. kW = BHP x 0.932.

ZJ150 (12.5 Ton) Side Duct

Air Flow (CFM)	Available External Static Pressure - IWG ¹																			
	0.2		0.4		0.6		0.8		1.0		1.2		1.4		1.6		1.8		2.0	
	RPM	BHP	RPM	BHP	RPM	BHP	RPM	BHP	RPM	BHP	RPM	BHP	RPM	BHP	RPM	BHP	RPM	BHP	RPM	BHP
	Field Supplied Drive				Standard 3 HP & Drive								Hi Static 5 HP & Drive							
3200	713	0.88	764	1.09	814	1.28	861	1.47	907	1.65	952	1.83	995	2.00	1037	2.17	1079	2.34	1119	2.52
3400	728	1.02	779	1.23	829	1.43	877	1.61	923	1.79	967	1.97	1010	2.14	1053	2.31	1094	2.48	1135	2.66
3600	745	1.18	796	1.39	846	1.59	893	1.77	939	1.95	984	2.13	1027	2.30	1069	2.47	1111	2.64	1152	2.82
3800	763	1.36	815	1.57	864	1.76	912	1.95	958	2.13	1002	2.31	1046	2.48	1088	2.65	1129	2.82	1170	3.00
4000	783	1.55	835	1.76	884	1.96	932	2.15	978	2.33	1022	2.50	1066	2.67	1108	2.84	1149	3.02	1190	3.19
4200	805	1.77	856	1.98	906	2.17	953	2.36	999	2.54	1044	2.72	1087	2.89	1129	3.06	1171	3.23	1211	3.41
4400	828	2.00	879	2.21	929	2.41	976	2.59	1022	2.77	1067	2.95	1110	3.12	1152	3.29	1194	3.46	1235	3.64
4600	852	2.25	904	2.46	953	2.66	1001	2.85	1047	3.03	1092	3.20	1135	3.37	1177	3.54	1219	3.72	1259	3.89
4800	879	2.52	930	2.73	980	2.93	1027	3.12	1073	3.30	1118	3.47	1161	3.65	1203	3.82	1245	3.99	1285	4.16
5000	906	2.81	958	3.02	1007	3.22	1055	3.41	1101	3.59	1146	3.76	1189	3.94	1231	4.11	1273	4.28	1313	4.45
5200	936	3.12	987	3.33	1037	3.53	1084	3.72	1130	3.90	1175	4.07	1218	4.24	1260	4.42	1302	4.59	1343	4.76
5400	966	3.45	1018	3.66	1067	3.86	1115	4.05	1161	4.23	1206	4.40	1249	4.57	1291	4.74	1333	4.91	1373	5.09
5600	999	3.80	1050	4.01	1100	4.20	1147	4.39	1193	4.57	1238	4.75	1281	4.92	1323	5.09	1365	5.26	1405	5.44
5800	1032	4.16	1084	4.37	1133	4.57	1181	4.75	1227	4.93	1271	5.11	1315	5.28	1357	5.45	1398	5.62	-	-
6000	1067	4.54	1119	4.75	1168	4.95	1216	5.13	1262	5.31	1306	5.49	1350	5.66	-	-	-	-	-	-
6200	1103	4.94	1155	5.15	1204	5.34	1252	5.53	1298	5.71	-	-	-	-	-	-	-	-	-	-
													5 HP & Field Supplied Drive							

1. Blower performance includes gas heat exchangers and 2" filters. See STATIC RESISTANCE table for additional applications.
2. See RPM SELECTION table to determine desired motor sheave setting and to determine the maximum continuous BHP.
3. kW = BHP x 0.932.

Table 17: Airflow Performance - Bottom Duct Application
ZJ078 (6.5 Ton) Bottom Duct

Air Flow (CFM)	Available External Static Pressure - IWG ¹																			
	0.2		0.4		0.6		0.8		1.0		1.2		1.4		1.6		1.8		2.0	
	RPM	BHP	RPM	BHP	RPM	BHP	RPM	BHP	RPM	BHP	RPM	BHP	RPM	BHP	RPM	BHP	RPM	BHP	RPM	BHP
	FS ⁴		Standard 1.5 HP & Drive										Hi Static 2 HP & Drive							
1800	603	0.13	656	0.36	718	0.58	784	0.79	851	0.98	914	1.16	968	1.31	1010	1.43	1035	1.53	1039	1.59
2000	627	0.26	680	0.49	742	0.71	808	0.92	875	1.12	937	1.29	992	1.44	1034	1.57	1059	1.66	1063	1.72
2200	650	0.40	703	0.63	765	0.85	831	1.06	898	1.25	961	1.43	1015	1.58	1057	1.71	1082	1.80	1086	1.86
2400	673	0.55	726	0.78	788	1.00	854	1.21	921	1.40	984	1.58	1038	1.73	1080	1.85	1105	1.95	1109	2.01
2600	696	0.71	749	0.94	811	1.16	878	1.37	944	1.56	1007	1.73	1061	1.89	1103	2.01	1128	2.10	1133	2.16
2800	720	0.87	773	1.10	835	1.32	902	1.53	968	1.73	1031	1.90	1085	2.05	1127	2.18	1152	2.27	1157	2.33
3000	745	1.05	798	1.28	860	1.50	926	1.71	993	1.91	1056	2.08	1110	2.23	1152	2.36	1177	2.45	1181	2.51
3200	771	1.24	824	1.47	886	1.69	952	1.90	1019	2.09	1081	2.27	1136	2.42	1178	2.54	1203	2.64	1207	2.70
3400	797	1.44	850	1.67	912	1.89	979	2.10	1045	2.29	1108	2.47	1162	2.62	1204	2.74	1229	2.84	1234	2.90
	3 HP & Field Supplied Drive																			

1. Blower performance includes gas heat exchangers and 2" filters. See STATIC RESISTANCE table for additional applications.
2. See RPM SELECTION table to determine desired motor sheave setting and to determine the maximum continuous BHP.
3. kW = BHP x 0.932.
4. Field Supplied Drive.

ZJ090 (7.5 Ton) Bottom Duct

Air Flow (CFM)	Available External Static Pressure - IWG ¹																			
	0.2		0.4		0.6		0.8		1.0		1.2		1.4		1.6		1.8		2.0	
	RPM	BHP	RPM	BHP	RPM	BHP	RPM	BHP	RPM	BHP	RPM	BHP	RPM	BHP	RPM	BHP	RPM	BHP	RPM	BHP
	FS ⁴		Standard 1.5 HP & Drive										Hi Static 3 HP & Drive							
2000	644	0.11	698	0.38	755	0.62	814	0.85	874	1.06	933	1.26	990	1.46	1043	1.66	1090	1.87	1131	2.09
2200	666	0.26	720	0.53	777	0.77	836	1.00	896	1.21	956	1.41	1012	1.61	1065	1.81	1113	2.02	1153	2.24
2400	689	0.42	743	0.69	800	0.93	859	1.16	919	1.37	978	1.57	1035	1.77	1088	1.97	1135	2.18	1176	2.40
2600	712	0.60	766	0.87	823	1.11	882	1.34	942	1.55	1002	1.75	1058	1.95	1111	2.15	1159	2.36	1199	2.58
2800	736	0.80	790	1.06	847	1.31	906	1.53	967	1.74	1026	1.94	1082	2.14	1135	2.34	1183	2.55	1223	2.78
3000	761	1.00	815	1.27	872	1.52	931	1.74	991	1.95	1051	2.15	1107	2.35	1160	2.55	1208	2.76	1248	2.98
3200	787	1.22	840	1.49	898	1.74	957	1.96	1017	2.17	1076	2.37	1133	2.57	1186	2.77	1233	2.98	1274	3.20
3400	813	1.46	867	1.73	924	1.97	984	2.19	1044	2.40	1103	2.61	1160	2.80	1212	3.01	1260	3.21	-	-
3600	841	1.70	894	1.97	952	2.21	1011	2.44	1071	2.65	1130	2.85	1187	3.05	-	-	-	-	-	-
3800	869	1.96	923	2.22	980	2.47	1039	2.69	1099	2.90	1158	3.10	1215	3.30	-	-	-	-	-	-
	3 HP & Field Supplied Drive																			

1. Blower performance includes gas heat exchangers and 2" filters. See STATIC RESISTANCE table for additional applications.
2. See RPM SELECTION table to determine desired motor sheave setting and to determine the maximum continuous BHP.
3. kW = BHP x 0.932.
4. Field Supplied Drive.

ZJ102 (8.5 Ton) Bottom Duct

Air Flow (CFM)	Available External Static Pressure - IWG ¹																			
	0.2		0.4		0.6		0.8		1.0		1.2		1.4		1.6		1.8		2.0	
	RPM	BHP	RPM	BHP	RPM	BHP	RPM	BHP	RPM	BHP	RPM	BHP	RPM	BHP	RPM	BHP	RPM	BHP	RPM	BHP
	FS ⁴		Standard 2 HP & Drive										Hi Static 3 HP & Drive							
2200	685	0.59	739	0.74	791	0.88	841	1.01	889	1.14	936	1.27	981	1.39	1025	1.51	1069	1.63	1111	1.75
2400	702	0.70	756	0.85	808	0.99	858	1.12	906	1.25	953	1.37	999	1.49	1043	1.62	1086	1.74	1129	1.86
2600	722	0.83	776	0.97	828	1.11	878	1.25	926	1.37	973	1.50	1018	1.62	1063	1.74	1106	1.86	1149	1.99
2800	744	0.97	798	1.12	850	1.26	900	1.39	949	1.52	995	1.64	1041	1.76	1085	1.88	1128	2.00	1171	2.13
3000	769	1.13	823	1.28	875	1.42	925	1.55	974	1.68	1020	1.80	1066	1.92	1110	2.05	1153	2.17	1196	2.29
3200	797	1.32	851	1.46	903	1.60	953	1.74	1001	1.86	1048	1.99	1093	2.11	1138	2.23	1181	2.35	1224	2.48
3400	828	1.52	882	1.67	934	1.81	983	1.94	1032	2.07	1078	2.19	1124	2.32	1168	2.44	1212	2.56	1254	2.68
3600	861	1.75	915	1.90	967	2.04	1017	2.17	1065	2.30	1112	2.42	1157	2.54	1201	2.67	1245	2.79	1287	2.91
3800	897	2.00	951	2.15	1002	2.29	1052	2.42	1101	2.55	1147	2.67	1193	2.80	1237	2.92	1280	3.04	1323	3.16
4000	935	2.27	989	2.42	1041	2.56	1091	2.69	1139	2.82	1186	2.95	1231	3.07	1275	3.19	1319	3.31	1362	3.43
4200	976	2.57	1030	2.72	1082	2.86	1132	2.99	1180	3.12	1227	3.24	1272	3.36	-	-	-	-	-	-
	3 HP & Field Supplied Drive																			

1. Blower performance includes gas heat exchangers and 2" filters. See STATIC RESISTANCE table for additional applications.
2. See RPM SELECTION table to determine desired motor sheave setting and to determine the maximum continuous BHP.
3. kW = BHP x 0.932.
4. Field Supplied Drive.

ZJ120 (10 Ton) Bottom Duct

Air Flow (CFM)	Available External Static Pressure - IWG ¹																			
	0.2		0.4		0.6		0.8		1.0		1.2		1.4		1.6		1.8		2.0	
	RPM	BHP	RPM	BHP	RPM	BHP	RPM	BHP	RPM	BHP	RPM	BHP	RPM	BHP	RPM	BHP	RPM	BHP	RPM	BHP
	Field Supplied Drive		Standard 2 HP & Drive								Hi Static 3 HP & Drive									
2600	722	0.83	776	0.97	828	1.11	878	1.25	926	1.37	973	1.50	1018	1.62	1063	1.74	1106	1.86	1149	1.99
2800	744	0.97	798	1.12	850	1.26	900	1.39	949	1.52	995	1.64	1041	1.76	1085	1.88	1128	2.00	1171	2.13
3000	769	1.13	823	1.28	875	1.42	925	1.55	974	1.68	1020	1.80	1066	1.92	1110	2.05	1153	2.17	1196	2.29
3200	797	1.32	851	1.46	903	1.60	953	1.74	1001	1.86	1048	1.99	1093	2.11	1138	2.23	1181	2.35	1224	2.48
3400	828	1.52	882	1.67	934	1.81	983	1.94	1032	2.07	1078	2.19	1124	2.32	1168	2.44	1212	2.56	1254	2.68
3600	861	1.75	915	1.90	967	2.04	1017	2.17	1065	2.30	1112	2.42	1157	2.54	1201	2.67	1245	2.79	1287	2.91
3800	897	2.00	951	2.15	1002	2.29	1052	2.42	1101	2.55	1147	2.67	1193	2.80	1237	2.92	1280	3.04	1323	3.16
4000	935	2.27	989	2.42	1041	2.56	1091	2.69	1139	2.82	1186	2.95	1231	3.07	1275	3.19	1319	3.31	1362	3.43
4200	976	2.57	1030	2.72	1082	2.86	1132	2.99	1180	3.12	1227	3.24	1272	3.36	-	-	-	-	-	-
4400	1019	2.88	1073	3.03	1125	3.17	1175	3.30	1223	3.43	-	-	-	-	-	-	-	-	-	-
4600	1065	3.22	1119	3.36	-	-	-	-	-	-	-	-	-	-	-	-	-	-	-	-
	3 HP & Field Supplied Drive																			

1. Blower performance includes gas heat exchangers and 2" filters. See STATIC RESISTANCE table for additional applications.
2. See RPM SELECTION table to determine desired motor sheave setting and to determine the maximum continuous BHP.
3. kW = BHP x 0.932.

ZJ150 (12.5 Ton) Bottom Duct

Air Flow (CFM)	Available External Static Pressure - IWG ¹																			
	0.2		0.4		0.6		0.8		1.0		1.2		1.4		1.6		1.8		2.0	
	RPM	BHP	RPM	BHP	RPM	BHP	RPM	BHP	RPM	BHP	RPM	BHP	RPM	BHP	RPM	BHP	RPM	BHP	RPM	BHP
	Field Supplied Drive		Standard 3 HP & Drive								Hi Static 5 HP & Drive									
3200	797	1.32	851	1.46	903	1.60	953	1.74	1001	1.86	1048	1.99	1093	2.11	1138	2.23	1181	2.35	1224	2.48
3400	828	1.52	882	1.67	934	1.81	983	1.94	1032	2.07	1078	2.19	1124	2.32	1168	2.44	1212	2.56	1254	2.68
3600	861	1.75	915	1.90	967	2.04	1017	2.17	1065	2.30	1112	2.42	1157	2.54	1201	2.67	1245	2.79	1287	2.91
3800	897	2.00	951	2.15	1002	2.29	1052	2.42	1101	2.55	1147	2.67	1193	2.80	1237	2.92	1280	3.04	1323	3.16
4000	935	2.27	989	2.42	1041	2.56	1091	2.69	1139	2.82	1186	2.95	1231	3.07	1275	3.19	1319	3.31	1362	3.43
4200	976	2.57	1030	2.72	1082	2.86	1132	2.99	1180	3.12	1227	3.24	1272	3.36	1316	3.48	1360	3.60	1402	3.73
4400	1019	2.88	1073	3.03	1125	3.17	1175	3.30	1223	3.43	1270	3.55	1315	3.67	1360	3.80	1403	3.92	1446	4.04
4600	1065	3.22	1119	3.36	1171	3.50	1221	3.64	1269	3.76	1316	3.89	1361	4.01	1405	4.13	1449	4.25	1491	4.38
4800	1113	3.57	1167	3.72	1219	3.86	1269	3.99	1317	4.12	1364	4.24	1409	4.36	1453	4.48	1497	4.61	1540	4.73
5000	1163	3.94	1217	4.09	1269	4.23	1319	4.36	1367	4.49	1414	4.62	1459	4.74	1504	4.86	1547	4.98	1590	5.10
5200	1216	4.34	1270	4.48	1321	4.62	1371	4.76	1420	4.88	1466	5.01	1512	5.13	1556	5.25	1600	5.37	1642	5.50
5400	1270	4.75	1324	4.89	1376	5.03	1426	5.17	1474	5.29	1521	5.42	1566	5.54	1611	5.66	-	-	-	-
5600	1327	5.17	1381	5.32	1433	5.46	1483	5.59	1531	5.72	-	-	-	-	-	-	-	-	-	-
5800	1385	5.62	-	-	-	-	-	-	-	-	-	-	-	-	-	-	-	-	-	-
	5 HP & Field Supplied Drive																			

1. Blower performance includes gas heat exchangers and 2" filters. See STATIC RESISTANCE table for additional applications.
2. See RPM SELECTION table to determine desired motor sheave setting and to determine the maximum continuous BHP.
3. kW = BHP x 0.932.

Table 18: RPM Selection

Size (Tons)	Model	HP	Max BHP	Motor Sheave	Blower Sheave	6 Turns Open	5 Turns Open	4 Turns Open	3 Turns Open	2 Turns Open	1 Turn Open	Fully Closed
078 (6.5)	ZJ	1.5	1.73	1VL40	AK74	N/A	641	690	739	789	838	887
		2	2.30	1VM50	AK74	N/A	887	936	986	1035	1084	1134
090 (7.5)	ZJ	1.5	1.73	1VL40	AK69	N/A	690	743	796	849	902	955
		3	3.45	1VM50	AK69	N/A	955	1008	1062	1115	1168	1221
102 (8.5)	ZJ	2	2.30	1VM50	AK89	N/A	731	771	812	852	893	934
		3	3.45	1VM50	AK74	N/A	887	936	986	1035	1084	1134
120 (10)	ZJ	2	2.30	1VM50	AK84	N/A	776	819	863	906	949	992
		3	3.45	1VM50	AK74	N/A	887	936	986	1035	1084	1134
150 (12.5)	ZJ	3	3.45	1VM50	AK74	N/A	887	936	986	1035	1084	1134
		5	5.75	1VP56	BK77	1052	1095	1136	1175	1216	1272	N/A

Table 19: Indoor Blower Specifications

Size (Tons)	Model	Motor					Motor Sheave			Blower Sheave			Belt
		HP	RPM	Eff.	SF	Frame	Datum Dia. (in.)	Bore (in.)	Model	Datum Dia. (in.)	Bore (in.)	Model	
078 (6.5)	ZJ	1-1/2	1725	0.8	1.15	56	2.6 - 3.6	7/8	1VL40	7.0	1	AK74	A53
		2	1725	0.8	1.15	56	3.6 - 4.6	7/8	1VM50	7.0	1	AK74	A54
090 (7.5)	ZJ	1-1/2	1725	0.8	1.15	56	2.6 - 3.6	7/8	1VL40	6.5	1	AK69	A53
		3	1725	0.8	1.15	56	3.6 - 4.6	7/8	1VM50	6.5	1	AK69	A54
102 (8.5)	ZJ	2	1725	0.8	1.15	56	3.4 - 4.4	7/8	1VM50	8.5	1	AK89	A56
		3	1725	0.8	1.15	56	3.4 - 4.4	7/8	1VM50	7.0	1	AK74	A54
120 (10)	ZJ	2	1725	0.8	1.15	56	3.4 - 4.4	7/8	1VM50	8.0	1	AK84	A56
		3	1725	0.8	1.15	56	3.4 - 4.4	7/8	1VM50	7.0	1	AK74	A54
150 (12.5)	ZJ	3	1725	0.8	1.15	56	3.4 - 4.4	7/8	1VM50	7.0	1	AK74	A54
		5	1725	0.87	1.15	184T	4.3 - 5.3	1-1/8	1VP56	6.7	1	BK77	BX55

Table 20: Power Exhaust Specifications

Model	Voltage	Motor			Motor			Fuse Size	CFM @ 0.1 ESP
		HP	RPM ¹	QTY	LRA	FLA	MCA		
2PE04703225	208/230-1-60	3/4	1075	1	7.8	5	6.3	10	3800
2PE04703246	460-1-60	3/4	1075	1	3.4	2.2	2.8	5	3800
2PE04703258	575-1-60	3/4	1050	1	2.9	1.5	1.9	4	3800

1. Motors are multi-tapped and factory wired for high speed.

Air Balance

CAUTION

On VAV units be certain that the VFD is set to maximum output, exhaust dampers are closed and individual space damper boxes are full open.

VFD units with manual bypass option must not be in the bypass mode ("LINE" position), unless all individual space dampers are full open.

Start the supply air blower motor. Adjust the resistances in both the supply and the return air duct systems to balance the air distribution throughout the conditioned space. The job specifications may require that this balancing be done by someone other than the equipment installer.

CAUTION

Belt drive blower systems MUST be adjusted to the specific static and CFM requirements for the application. The Belt drive blowers are NOT set at the factory for any specific static or CFM. Adjustments of the blower speed and belt tension are REQUIRED. Verify proper sheave alignment; tighten blower pulley and motor sheave set screws after these adjustments. Re-checking set screws after 10-12 hrs. run time is recommended.

Checking Air Quantity

Method One

1. Remove the dot plugs from the duct panel (for location of the dot plugs see Figures 12 and 13).
2. Insert eight-inches of 1/4 inch metal tubing into the airflow on both sides of the indoor coil.

NOTE: The tubes must be inserted and held in a position perpendicular to the air flow so that velocity pressure will not affect the static pressure readings.

3. Use an Inclined Manometer or Magnehelic to determine the pressure drop across a dry evaporator coil. Since the moisture on an evaporator coil can vary greatly, measuring the pressure drop across a wet coil under field conditions could be inaccurate. To assure a dry coil, the compressors should be de-activated while the test is being run.

NOTE: De-energize the compressors before taking any test measurements to assure a dry evaporator coil.

4. The CFM through the unit can be determined from the pressure drop indicated by the manometer by referring to Figure 31. In order to obtain an accurate measurement, be certain that the air filters are clean.
5. To adjust Measured CFM to Required CFM, see SUPPLY AIR DRIVE ADJUSTMENT.
6. After readings have been obtained, remove the tubes and replace the dot plugs.
7. Tighten blower pulley and motor sheave set screws after any adjustments. Re-check set screws after 10-12 hrs. run time is recommended.

WARNING

Failure to properly adjust the total system air quantity can result in extensive blower damage.

Method Two

1. Drill two 5/16 inch holes, one in the return air duct as close to the inlet of the unit as possible, and another in the supply air duct as close to the outlet of the unit as possible.
2. Using the whole drilled in step 1, insert eight inches of 1/4 inch metal tubing into the airflow of the return and supply air ducts of the unit.

NOTE: The tubes must be inserted and held in position perpendicular to the airflow so that velocity pressure will not affect the static pressure readings.

3. Use an Inclined Manometer or Magnehelic to determine the pressure drop across the unit. This is the External Static Pressure (ESP). In order to obtain an accurate measurement, be certain that the air filters are clean.
4. Determine the number of turns the variable motor sheave is open.

5. Select the correct blower performance table for the unit from Tables 16 and 17. Tables are presented for side and downflow configuration.
6. Determine the unit Measured CFM from the Blower Performance Table, External Static Pressure and the number of turns the variable motor sheave is open.
7. To adjust Measured CFM to Required CFM, see SUPPLY AIR DRIVE ADJUSTMENT.
8. After reading has been obtained, remove the tubes and seal holes.
9. Tighten blower pulley and motor sheave set screws after any adjustments. Re-check set screws after 10-12 hrs. run time is recommended.

NOTE: With the addition of field installed accessories repeat this procedure.

WARNING

Failure to properly adjust the total system air quantity can result in extensive blower damage.

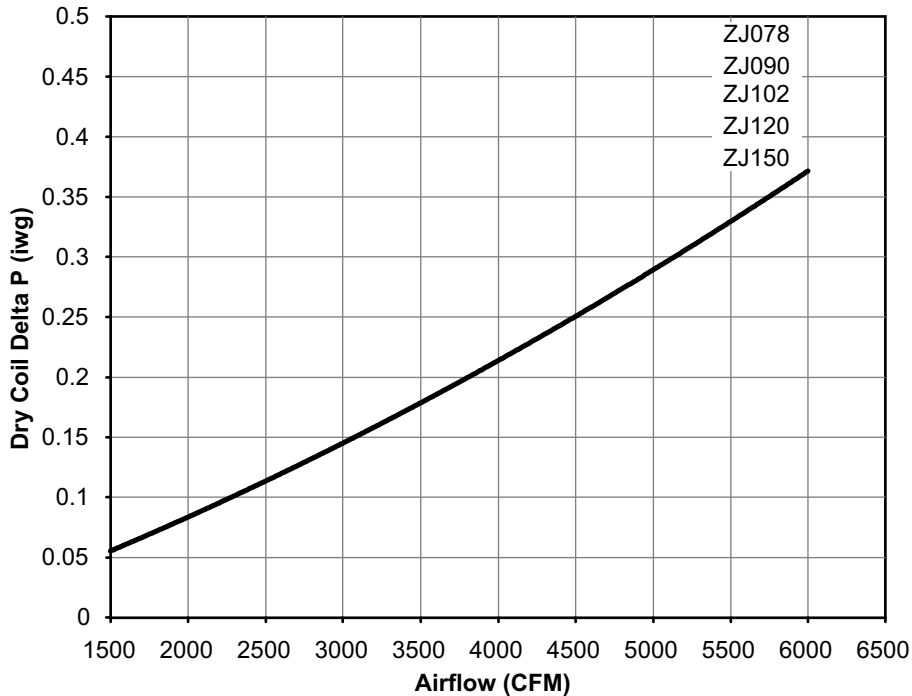

Figure 31: Dry Coil Delta P

Supply Air Drive Adjustment

CAUTION

Before making any blower speed changes review the installation for any installation errors, leaks or undesirable systems effects that can result in loss of airflow.

Even small changes in blower speed can result in substantial changes in static pressure and BHP. BHP and AMP draw of the blower motor will increase by the cube of the blower speed. Static pressure will increase by the square of the blower speed. Only qualified personnel should make blower speed changes, strictly adhering to the fan laws.

At unit start-up, the measured CFM may be higher or lower than the required CFM. To achieve the required CFM, the speed of the drive may have adjusted by changing the datum diameter (DD) of the variable pitch motor sheave as described below:

$$\left(\frac{4,000 \text{ CFM}}{3,800 \text{ CFM}} \right) \cdot 4.0 \text{ in.} = 4.21 \text{ in.}$$

Use the following tables and the DD calculated per the above equation to adjust the motor variable pitch sheave.

Table 21: Motor Sheave Datum Diameters

1VM50x7/8 (1-1/2, 2 & 3 HP Motor)		1VP56x1-1/8 (5 HP Motor)	
Turns Open	Datum Diameter	Turns Open	Datum Diameter
0	4.4	1	5.3
1/2	4.3	1-1/2	5.2
1	4.2	2	5.1
1-1/2	4.1	2-1/2	5.0
2	4.0	3	4.9
2-1/2	3.9	3-1/2	4.8
3	3.8	4	4.7
3-1/2	3.7	4-1/2	4.6
4	3.6	5	4.5
4-1/2	3.5	5-1/2	4.4
5	3.4	6	4.3

CAUTION

Belt drive blower systems **MUST** be adjusted to the specific static and CFM requirements for the application. The Belt drive blowers are **NOT** set at the factory for any specific static or CFM. Adjustments of the blower speed and belt tension are **REQUIRED**. Verify proper sheave alignment; tighten blower pulley and motor sheave set screws after these adjustments. Re-checking set screws after 10-12 hrs. run time is recommended.

EXAMPLE

A 12.5 ton unit was selected to deliver 4,000 CFM with a 3 HP motor, but the unit is delivering 3,800 CFM. The variable pitch motor sheave is set at 2 turns open.

Use the equation to determine the required DD for the new motor sheave,

$$\left(\frac{\text{Required CFM}}{\text{Measured CFM}} \right) \cdot \text{Existing DD} = \text{New DD}$$

Use Table 21 to locate the DD nearest to 4.21 in. Close the sheave to 1 turn open.

New BHP

$$= (\text{Speed increase})^3 \cdot \text{BHP at 3,800 CFM}$$

$$= (\text{Speed increase})^3 \cdot \text{Original BHP}$$

$$= \text{New BHP}$$

New motor Amps

$$= (\text{Speed increase})^3 \cdot \text{Amps at 3,800 CFM}$$

$$= (\text{Speed increase})^3 \cdot \text{Original Amps}$$

$$= \text{New Amps}$$

Table 22: Additional Static Resistance

Size (Tons)	Model	CFM	Cooling Only ¹	Economizer ^{2,3}	4" Filter ²	Electric Heat kW ²				
						9	18	24	36	54
078 (6.5) 090 (7.5) 102 (8.5) 120 (10) 150 (12.5)	ZJ	1900	0.06	0.02	0.12	0.05	0.06	0.07	0.08	0.10
		2100	0.07	0.02	0.13	0.06	0.07	0.08	0.09	0.11
		2300	0.08	0.04	0.14	0.07	0.08	0.09	0.10	0.13
		2500	0.09	0.11	0.16	0.08	0.09	0.10	0.11	0.14
		2700	0.11	0.18	0.17	0.09	0.10	0.12	0.13	0.16
		2900	0.12	0.25	0.19	0.10	0.11	0.13	0.14	0.18
		3100	0.14	0.31	0.20	0.12	0.13	0.15	0.16	0.20
		3300	0.16	0.37	0.22	0.13	0.14	0.17	0.18	0.22
		3500	0.18	0.43	0.26	0.15	0.16	0.19	0.20	0.24
		3700	0.20	0.49	0.27	0.17	0.18	0.21	0.22	0.26
		3900	0.23	0.54	0.29	0.19	0.20	0.23	0.24	0.28
		4100	0.25	0.58	0.32	0.21	0.22	0.25	0.26	0.31
		4300	0.28	0.65	0.35	0.23	0.24	0.28	0.29	0.34
		4500	0.30	0.69	0.38	0.25	0.26	0.30	0.31	0.37
		4700	0.33	0.74	0.41	0.28	0.29	0.33	0.34	0.40
		4900	0.36	0.78	0.44	0.30	0.31	0.35	0.37	0.43
		5100	0.39	0.82	0.47	0.33	0.34	0.38	0.40	0.46
		5300	0.42	0.86	0.51	0.35	0.37	0.41	0.43	0.49
		5500	0.45	0.89	0.55	0.38	0.40	0.44	0.46	0.53
		5700	0.48	0.93	0.58	0.41	0.43	0.47	0.49	0.56
5900	0.52	0.96	0.62	0.44	0.46	0.50	0.53	0.59		
6100	0.56	0.98	0.67	0.47	0.49	0.53	0.56	0.62		
6300	0.60	1.01	0.71	0.50	0.53	0.56	0.59	0.65		

1. Add these values to the available static resistance in the respective Blower Performance Tables.
2. Deduct these values from the available external static pressure shown in the respective Blower Performance Tables.
3. The pressure drop through the economizer is greater for 100% outdoor air than for 100% return air. If the resistance of the return air duct is less than 0.25 IWG, the unit will deliver less CFM during full economizer operation.

Operation

Cooling Sequence Of Operation

NOTE: For more in-depth sequence of operation of the Simplicity® SE control please refer to LIT-12011950 on www.upgnet.com under Product Center \ Equipment Catalog \ Commercial Products \ Zoning Systems and Controls.

For ZJ units, a "Y1" call for the first stage of cooling is passed to the Unit Control Board (UCB) which then determines whether the requested operation is available and if so, which components to energize. With a "Y1" call for first stage cooling the UCB will determine if a first stage cooling output is valid as long as all safeties and time-delays allow a C1 output for cooling. The C1 relay on the UCB will close and send 24 volts to the M1 relay starting the first stage compressor and also energizing M4 relay starting the associated condenser fans. During any call for fan or cooling the FAN output on the UCB will energize the M3 relay starting the supply fan.

If a Y2 call is present it is passed to the Unit Control Board (UCB) which then determines whether the requested operation is available and if so, which components to energize. With a "Y2" call for first stage cooling the UCB will determine if a

second stage cooling output is valid as long as all safeties and time-delays allow a C2 output for cooling. The C2 relay on the UCB will close and send 24v to the M2 relay starting the second stage compressor also energizing M6 relay starting the associated condenser fans. During any call for fan or cooling the FAN output on the UCB will energize the M3 relay starting the supply fan.

Continuous Blower

By setting the room thermostat fan switch to "ON," the supply air blower will operate continuously.

Intermittent Blower

With the room thermostat fan switch set to "AUTO" and the system switch set to either the "AUTO" or "HEAT" settings, the blower is energized whenever a cooling or heating operation is requested. The blower is energized after any specified delay associated with the operation.

When energized, the indoor blower has a minimum run time of 30 seconds. Additionally, the indoor blower has a delay of 10 seconds minimum off.

Optional VAV Start-up and Control

CAUTION

If the unit is operated with the optional manual bypass switch in the LINE (BYPASS) position and there are VAV boxes present in the duct system, then boxes must be driven to the full-open position using a customer-supplied power source to prevent over-pressurizing and possible damage to the ductwork.

Once placed into the Occupied Mode, the speed of the indoor blower motor is controlled by duct static pressure. The Duct Static set point (default = 1.5") is the pressure that the VFD drive will maintain when operating the unit in VAV mode. If the duct static pressure reaches or exceeds the high-limit set-point (default = 4.5"), then the supply fan motor will be shutdown.

The Supply Air Temperature (SAT) is controlled by staging compressors on and off to satisfy the "Operating Cooling Supply Air Temp Set point". There are 3 set points that determine the resulting "Operating Cooling Supply Air Temp Set point".

1. VAV Cooling Supply Air Temp Upper Set point (default 60° F)
2. VAV Cooling Supply Air Temp Lower Set point (default 55° F)
3. VAV Supply Air Temp Reset Set point (default 72° F)

When the Return Air Temp (RAT) is above the "VAV Supply Air Temp Reset Set point" the SAT will be maintained at +/- 5 degrees of the "VAV Cooling Supply Air Temp Lower Set point".

When the Return Air Temp (RAT) is below the "VAV Supply Air Temp Reset Set point" the SAT will be maintained at +/- 5 degrees of the "VAV Cooling Supply Air Temp Upper Set point".

When the Outdoor air condition is sufficient for free cooling, the economizer will modulate to control the SAT to +/- 1 degrees of the operational set point.

No Outdoor Air Options

When the thermostat calls for the first stage of cooling, the low-voltage control circuit from "R" to "Y1" and "G" is completed. The UCB energizes the economizer (if installed and free cooling is available) or the first available compressor* and the condenser fans. For first stage cooling, compressor #1 is energized. If compressor #1 is unavailable, compressor #2 is energized. After completing the specified fan on delay for cooling, the UCB will energize the blower motor.

When the thermostat calls for the second stage of cooling, the low-voltage control circuit from "R" to "Y2" is completed. The control board energizes the first available compressor. If free cooling is being used for the first stage of cooling, compressor #1 is energized. If compressor #1 is active for first stage cooling or the first compressor is locked-out, compressor #2 is energized. In free-cooling mode, if the call for the second stage

of cooling continues for 20 minutes, compressor #2 is energized, provided it has not been locked-out.

If there is an initial call for both stages of cooling, the UCB will delay energizing compressor #2 by 30 seconds in order to avoid a power rush.

Once the thermostat has been satisfied, it will de-energize Y1 and Y2. If the compressors have satisfied their minimum run times, the compressors and condenser fans are de-energized. Otherwise, the unit operates each cooling system until the minimum run times for the compressors have been completed. Upon the final compressor de-energizing, the blower is stopped following the elapse of the fan off delay for cooling.

* To be available, a compressor must not be locked-out due to a high or low-pressure switch or the **Evaporator Low Limit Sensor (EC1, 2)** detects a temperature below 26 Deg. F and the **Anti-Short Cycle Delay (ASCD)** must have elapsed.

Economizer With Single Enthalpy Sensor

When the room thermostat calls for "first-stage" cooling, the low voltage control circuit from "R" to "G" and "Y1" is completed. The UCB energizes the blower motor (if the fan switch on the room thermostat is set in the "AUTO" position) and drives the economizer dampers from fully closed to their minimum position. If the enthalpy of the outdoor air is below the set point of the enthalpy controller (previously determined), "Y1" energizes the economizer. The dampers will modulate to maintain a constant supply air temperature as monitored by the discharge air sensor. If the outdoor air enthalpy is above the set point, "Y1" energizes compressor #1.

When the thermostat calls for "second-stage" cooling, the low voltage control circuit from "R" to "Y2" is completed. The UCB energizes the first available compressor. If the enthalpy of the outdoor air is below the set point of the enthalpy controller (i.e. first stage has energized the economizer), "Y2" will energize compressor #1. If the outdoor air is above the set point, "Y2" will energize compressor #2.

Once the thermostat has been satisfied, it will de-energize "Y1" and "Y2". If the compressors have satisfied their minimum run times, the compressors and condenser fans are de-energized. Otherwise, the unit operates each cooling system until the minimum run times for the compressors have been completed. Upon the final compressor de-energizing, the blower is stopped following the elapse of the fan off delay for cooling, and the economizer damper goes to the closed position. If the unit is in continuous fan operation, the economizer damper goes to the minimum position.

Economizer With Dual Enthalpy Sensors

The operation with the dual enthalpy sensors is identical to the single sensor except that a second enthalpy sensor is mounted in the return air. This return air sensor allows the economizer to choose between outdoor air and return air, whichever has the lowest enthalpy value, to provide maximum operating efficiency.

Economizer With Power Exhaust

A unit equipped with an economizer (single or dual enthalpy) and a power exhaust operates as specified above with one addition. The power exhaust motor is energized 45 seconds after the actuator position exceeds the exhaust fan set point on the economizer control. As always, the "R" to "G" connection provides minimum position but does not provide power exhaust operation.

Motorized Outdoor Air Dampers

This system operation is the same as the units with no outdoor air options with one exception. When the "R" to "G" circuit is complete, the motorized damper drives open to a position set by the thumbwheel on the damper motor. When the "R" to "G" circuit is opened, the damper spring returns fully closed.

Cooling Operation Errors

Each cooling system is monitored for operation outside of the intended parameters. Errors are handled as described below. All system errors override minimum run times for compressors.

NOTE: The following components are needed to access the control points in the Simplicity® SE control. Installation and operation guides are located on www.upgnet.com under Product Center \ Equipment Catalog \ Commercial Products \ Zoning Systems and Controls.

1. Local LCD on Unit Control Board.
OR
2. Mobile Access Portal (MAP) Gateway (Portable).
 - Source 1 P/N S1-JC-MAP1810-OP
3. MAP Gateway Quick Start Guide P/N 24-10737-16
4. MAP Gateway Instruction P/N 24-10737-8

High-Pressure Limit Switch

During cooling operation, if a high-pressure limit switch opens, the UCB will de-energize the associated compressor, initiate the ASCD (Anti-short cycle delay), and, if the other compressor is idle, stop the condenser fans. If the call for cooling is still present at the conclusion of the ASCD, the UCB will re-energize the halted compressor.

Should a high-pressure switch open three times within two hours of operation, the UCB will lock-out the associated compressor. If the other compressor is inactive, the condenser fans will be de-energized.

Low-Pressure Limit Switch

The low-pressure limit switch is not monitored during the initial 30 seconds of a cooling system's operation. For the following 30 seconds, the UCB will monitor the low-pressure switch to ensure it closes. If the low-pressure switch fails to close after the 30-second monitoring phase, the UCB will de-energize the associated compressor, initiate the ASCD, and, if the other compressor is idle, stop the condenser fans.

Once the low-pressure switch has been proven (closed during the 30-second monitor period described above), the UCB will monitor the low-pressure limit switch for any openings. If the low-pressure switch opens for greater than 5 seconds, the UCB will de-energize the associated compressor, initiate the ASCD, and, if the other compressor is idle, stop the condenser fans.

If the call for cooling is still present at the conclusion of the ASCD, the UCB will re-energize the halted compressor.

Should a low-pressure switch open three times within one hour of operation, the UCB will lock-out the associated compressor. If the other compressor is inactive, the condenser fans will be de-energized.

Evaporator Low Limit

During cooling operation, if the **Evaporator Low Limit Sensor (EC1, 2)** (Located on the Suction Line at the Evaporator Coil.) detects a temperature below 26 Deg. F (default), the UCB will de-energize the associated compressor, initiate the ASCD, and, if the other compressor is idle, stop the condenser fans. If the call for cooling is still present at the conclusion of the ASCD, the UCB will re-energize the halted compressor. Should the UCB detect the evaporator low limit sensor (**EC1, 2**) falling below 26 Deg. F (default) three times within two hours of operation, the UCB will lock-out the associated compressor. If the other compressor is inactive, the condenser fans will be de-energized.

Low Ambient Cooling

To determine when to operate in low ambient mode, the UCB has an **Outdoor Air Temperature Sensor (OAT)** with a low ambient setpoint at 45°F (default). When the **OAT Sensor** senses a temperature below the low ambient setpoint and the thermostat is calling for cooling, the UCB will operate in the low ambient mode.

Low ambient mode operates the compressors in this manner: 10 minutes on, 5 minutes off. The indoor blower is operated throughout the cycle. The 5-minute off period is necessary to defrost the indoor coil.

Low ambient mode always begins with compressor operation. Compressor minimum run time may extend the minutes of compressor operation. The off cycle will begin immediately following the elapse of the minimum run time.

When operating in low ambient mode, an evaporator low limit sensor (**EC1, 2**) temperature below 26°F will de-energize the associated compressor. If the call for cooling is still present at the end of the ASCD and the evaporator temperature sensor (**EC1, 2**) temperature is above 26°F, the unit will resume operation.

Safety Controls

The unit control board monitors the following inputs for each cooling system:

1. An evaporator low limit sensor (**EC1, 2**) (Located on the Suction Line at the Evaporator Coil.) to protect against low evaporator temperatures due to a low airflow or a low return air temperature, set at 26°F.

2. A high-pressure switch to protect against excessive discharge pressures due to a blocked condenser coil or a condenser motor failure, (opens at 625 ± 25 psig).
3. A low-pressure switch to protect against loss of refrigerant charge, (opens at 50 ± 5 psig).

The above pressure switches are hard-soldered to the unit. The refrigeration systems are independently monitored and controlled. On any fault, only the associated system will be affected by any safety/preventive action. The other refrigerant system will continue in operation unless it is affected by the fault as well.

The unit control board monitors the temperature limit switch of electric heat units and the temperature limit switch and the gas valve of gas furnace units.

Compressor Protection

In addition to the external pressure switches, the compressors also have inherent (internal) protection. If there is an abnormal temperature rise in a compressor, the protector will open to shut down the compressor. The UCB incorporates features to minimize compressor wear and damage. An **Anti-Short Cycle Delay (ASCD)** is utilized to prevent operation of a compressor too soon after its previous run. Additionally, a minimum run time is imposed any time a compressor is energized.

The ASCD is initiated on unit start-up and on any compressor reset or lock-out.

Electric Heating Sequence Of Operations

The following sequence describes the operation of the electric heat section.

CAUTION

For units with VFD and electric heat, the speed of the indoor blower motor continues to be controlled by duct static pressure via the VAV control board.

If there are VAV boxes present in the duct system, the boxes must be driven to the full-open position using a customer-supplied power source to assure adequate airflow across the heating elements.

Two-stage heating:

- a. Upon a call for first stage heat by the thermostat, the heater relay (RA) will be energized. After completing the specified fan on delay for heating, the UCB will energize the blower motor. If the second stage of heat is required, heater relay (RB) will be energized. After completing the specified fan on delay for heating, the UCB will energize the blower motor.
- b. The thermostat will cycle the electric heat to satisfy the heating requirements of the conditioned space.

Electric Heat Operation Errors

Temperature Limit

If the UCB senses zero volts from the high temperature limit, the indoor blower motor is immediately energized.

This limit is monitored regardless of unit operation status, i.e. the limit is monitored at all times.

If the temperature limit opens three times within one hour, it will lock-on the indoor blower motor.

Safety Controls

The UCB monitors the temperature limit switch of electric heat units.

The control circuit includes the following safety controls:

Limit Switch (LS)

This control is located inside the heater compartment and is set to open at the temperature indicated in the Electric Heat Limit Setting Tables 23. It resets automatically. The limit switch operates when a high temperature condition, caused by inadequate supply air flow occurs, thus shutting down the heater and energizing the blower.

Table 23: Electric Heat Limit Setting

UNIT (TONS)	VOLTAGE	HEATER KW	LIMIT SWITCH OPENS °F
ZJ078, 090 (6.5, 7.5)	208/230	9	150
		18	150
		24	150
		34	150
		18	150
		24	150
ZJ102, 120, 150 (8.5, 10, 12.5)	208/230	34	150
		54	130
		9	150
		18	150
		24	150
		34	150
ZJ078, 090 (6.5, 7.5)	480	34	150
		18	150
		24	150
		34	150
		54	130
		9	150
ZJ102, 120, 150 (8.5, 10, 12.5)	480	18	150
		24	150
		34	150
		54	130
		9	150
		18	150
ZJ078, 090 (6.5, 7.5)	600	24	150
		34	150
		18	150
		24	150
		34	150
		54	130
ZJ102, 120, 150 (8.5, 10, 12.5)	600	18	150
		24	150
		34	150
		54	130
		9	150
		18	150

Reset

Remove the call for heating by lowering the thermostat setting lower than the conditioned space temperature.

Electric Heat Anticipator Setpoints

It is important that the anticipator setpoint be correct. Too high of a setting will result in longer heat cycles and a greater temperature swing in the conditioned space. Reducing the value below the correct setpoint will give shorter “ON” cycles and may result in the lowering of the temperature within the conditioned space. Refer to Table 24 for the required electric heat anticipator setting.

Table 24: Electric Heat Anticipator Setpoints

SETTING, AMPS	
W1	W2
0.13	0.1

Gas Heating Sequence Of Operations

CAUTION

For units with VFD and gas heat, the speed of the indoor blower motor continues to be controlled by duct static pressure via the VAV control board.

If there are VAV boxes present in the duct system, the boxes must be driven to the full-open position using a customer-supplied power source to assure adequate airflow across the heat exchanger tubes.

When the thermostat calls for the first stage of heating, the low-voltage control circuit from “R” to “W1” is completed. A call for heat passes through the UCB to the **Ignition Control Board (ICB)**. The UCB monitors the “W1” call and acts upon any call for heat by monitoring the **Gas Valve (GV)**. Once voltage has been sensed at the GV, the UCB will initiate the fan on delay for heating, energizing the indoor blower the specified delay has elapsed.

When the thermostat has been satisfied, heating calls are ceased. The GV is immediately closed. The blower is de-energized after the fan off delay for heating has elapsed. The draft motor performs a 30-second post purge.

Ignition Control Board

First Stage Of Heating

When the ICB receives a call for first stage of heating, “W1,” the draft motor is energized. Once the draft motor has been proven, a 30-second purge is initiated. At the end of the purge, the GV is opened, and the spark igniter is energized for 10 seconds. The ICB then checks for the presence of flame. If flame is detected, the ICB enters a flame stabilization period. If flame was not detected, the GV closes, and a retry operation begins.

During the flame stabilization period, a loss of the flame for 2 seconds will cause the GV to close and the retry operation to begin. After the flame stabilization period, a loss of flame for 3/4 second will cause the GV to close and the retry operation to begin.

At the conclusion of the flame stabilization period, the ICB will operate the gas heat in high fire for an additional 60 seconds (for a total for 120 seconds of high fire operation). After this 60 seconds, the ICB will then use the call for the second stage of heat to control second stage operation of the GV.

When “W1” is satisfied, both valves are closed.

Second Stage Of Heating

When the ICB receives a call for the second stage of heating, “W2,” the ICB conducts a complete first stage ignition sequence. If this sequence is satisfied, the second main valve of the GV is opened.

When “W2” is satisfied, the second main valve is closed.

Retry Operation

When a flame is lost or is not detected during an attempt to achieve ignition, a retry operation occurs. A 30-second purge is performed between ignition attempts.

If the unit fails after three ignition attempts, the furnace is locked-out for one hour. The furnace is monitored during this one-hour period for unsafe conditions.

Recycle Operation

When a flame is lost after the flame stabilization period, a recycle operation occurs. If the unit fails after five recycle attempts, the furnace is locked-out for one hour.

Gas Heating Operation Errors

Lock-Out

A one-hour lockout occurs following three retries or five recycles. During the one-hour lockout, flame detection, limit conditions, and main valves are tested. Any improper results will cause the appropriate action to occur. Recycling the low voltage power cancels the lock-out.

Temperature Limit

If the UCB senses zero volts from the high temperature limit, the indoor blower motor is immediately energized. When the UCB again senses 24 volts from the temperature limit, the draft motor will perform a 15-second post-purge and the indoor blower will be de-energized following the elapse of the fan off delay for heating.

This limit is monitored regardless of unit operation status, i.e. this limit is monitored at all times.

If the temperature limit opens three times within one hour, it will lock-on the indoor blower motor and flash code is initiated (See Table 29).

Flame Sense

Flame sensing occurs at all times. If “W1” is not present and a flame is sensed for 2 seconds, the draft motor is energized and the GV is kept off. The ICB halts any operation until a flame is not detected. Once the flame detection is lost, the ICB performs

a post-purge. Normal operation is allowed concurrently with the purge (i.e. this purge can be considered the purge associated with a call for “W1”).

If “W1” is present, a flame is sensed, but the GV is not energized, the draft motor is energized until the flame detection is lost. Normal operation is now allowed.

The flame detection circuitry continually tests itself. If the ICB finds the flame detection circuitry to be faulty, the ICB will not permit an ignition sequence and the draft motor is energized. If this failure should occur during an ignition cycle the failure is counted as a recycle.

Gas Valve

The UCB and ICB continuously monitor the GV.

If the ICB senses voltage at the GV when not requested, the ICB will energize the draft motor. The ICB will not operate the furnace until voltage is no longer sensed at the GV. The draft motor is stopped when voltage is not sensed at the GV.

Any time the UCB senses voltage at the GV without a call for heat for a continuous five-minute period, the UCB will lock-on the indoor blower. When voltage is no longer sensed at the GV, the UCB will de-energize the indoor blower following the elapse of the fan off delay for heating.

If voltage has been sensed at the GV for at least 15 seconds during the fan on delay for heating and GV voltage or “W1” is lost, the indoor blower is forced on for the length of the fan off delay for heating.

During a call for heat, if the UCB does not sense voltage at the GV for a continuous five-minute period the UCB will initiate an error message. The indoor blower motor will not be locked-on while there is no GV voltage.

Safety Controls

The UCB monitors the temperature limit switch of gas heat units.

The control circuit includes the following safety controls:

Limit Switch (LS)

This control is located inside the gas heat compartment and is set to open at the temperature indicated in the Gas Heat Limit Control Settings Table 25. It resets automatically. The limit switch operates when a high temperature condition, caused by inadequate supply air flow occurs, thus shutting down the heater and energizing the blower.

Auxiliary Limit Switch (ALS)

This control is located inside the supply air compartment and is set to open at the temperature indicated in the Gas Heat Limit Control Settings Table 25. It resets manually. The limit switch operates when a high temperature condition, caused by

inadequate supply air flow occurs, thus shutting down the heater and energizing the blower.

The auxiliary limit switch is wired in series with the limit switch. As such, the UCB cannot distinguish the auxiliary limit and the gas heat limit switch operation except the auxiliary is manual reset. Consequently, the control will respond in the same manner as outlined above under “Limit Switch”.

Table 25: Gas Heat Limit Control Settings¹

Unit		Main Limit Setting °F
Size	Opt.	
ZJ078	N12	165
	N18	165
ZJ090	N12	165
	N18	165
ZJ102	N12	215
	N18	195
ZJ120	N18	195
	N24	160
ZJ150	N18	195
	N24	160

1. Roll-out = 300°F, Auxiliary Limit = 200°F.

The ICB monitors the Pressure and Roll-out switches of gas heat units.

The control circuit includes the following safety controls:

Pressure Switch (PS)

Once the draft motor has reached full speed and closes the pressure switch during a normal ignition sequence, if the pressure switch opens for 2 seconds, the GV will be de-energized, the ignition cycle is aborted, and the ICB flashes the appropriate code. See Table 30 Ignition Control Flash Codes. The draft motor is energized until the pressure switch closes or “W1” is lost.

Roll-out Switch (ROS)

The roll-out switch is wired in series with the pressure switch. As such, the ICB cannot distinguish the roll-out switch operation from that of the pressure switch.

Consequently, the control will only respond in the same manner as outlined above under “Pressure Switch”. An open roll-out will inhibit the gas valve from actuating.

Internal Microprocessor Failure

If the ICB detects an internal failure, it will cease all outputs, ignore inputs, and display the proper flash code for control replacement. The ICB remains in this condition until replaced.

Flash Codes

The ICB will initiate a flash code associated with errors within the system. Refer to IGNITION CONTROL FLASH CODES Table 30.

Resets

Remove the call for heating by lowering the thermostat setting lower than the conditioned space temperature. This resets any flash codes.

Gas Heat Anticipator Setpoints

It is important that the anticipator setpoint be correct. Too high of a setting will result in longer heat cycles and a greater temperature swing in the conditioned space. Reducing the value below the correct setpoint will give shorter "ON" cycles and may result in the lowering of the temperature within the conditioned space. Refer to Table 26 for the required gas heat anticipator setting.

Table 26: Gas Heat Anticipator Setpoints

SETTING, AMPS	
W1	W2
0.65	0.1

Start-Up (Cooling)

Prestart Check List

After installation has been completed:

1. Check the electrical supply voltage being supplied. Be sure that it is the same as listed on the unit nameplate.
2. Set the room thermostat to the off position.
3. Turn unit electrical power on.
4. Set the room thermostat fan switch to on.
5. Check indoor blower rotation.
 - If blower rotation is in the wrong direction. Refer to Phasing Section in general information section.
 Check blower drive belt tension.
6. Check the unit supply air (CFM).
7. Measure evaporator fan motor's amp draw.
8. Set the room thermostat fan switch to off.
9. Turn unit electrical power off.

Operating Instructions

1. Turn unit electrical power on.

NOTE: Prior to each cooling season, the crankcase heaters must be energized at least 10 hours before the system is put into operation.

2. Set the room thermostat setting to lower than the room temperature.
3. First stage compressors will energize after the built-in time delay (five minutes).
4. The second stage of the thermostat will energize second stage compressor if needed.

Post Start Check List

1. Verify proper system pressures for both circuits.
2. Measure the temperature drop across the evaporator coil.

Start-Up (Gas Heat)

Pre-Start Check List

Complete the following checks before starting the unit.

1. Check the type of gas being supplied. Be sure that it is the same as listed on the unit nameplate.
2. Make sure that the vent outlet and combustion air inlet are free of any debris or obstruction.

Operating Instructions

CAUTION

This furnace is equipped with an automatic re-ignition system. DO NOT attempt to manually light the pilot.

Lighting The Main Burners

1. Turn "OFF" electric power to unit.
2. Turn room thermostat to lowest setting.
3. Turn gas valve counter-clockwise to "ON" position (See Figure 33).
4. Turn "ON" electric power to unit.
5. If thermostat set temperature is above room temperature, the main burners will ignite. If a second stage of heat is called for, the main burners for second stage heat will ignite for the second stage heat.

Post Start Checklist

After the entire control circuit has been energized and the heating section is operating, make the following checks:

1. Check for gas leaks in the unit piping as well as the supply piping.

WARNING

FIRE OR EXPLOSION HAZARD

Failure to follow the safety warning exactly could result in serious injury, death or property damage.

Never test for gas leaks with an open flame. Use a commercially available soap solution made specifically for the detection of leaks to check all connections. A fire or explosion may result causing property damage, personal injury or loss of life.

2. Check for correct manifold gas pressures. (See CHECKING GAS INPUT.)
3. Check the supply gas pressure. It must be within the limits shown on the rating nameplate. Supply pressure should be

checked with all gas appliances in the building at full fire. At no time should the standby gas pressure exceed 10.5 in. or the operating pressure drop below 4.5 in for natural gas units. If gas pressure is outside these limits, contact the local gas utility or propane supplier for corrective action.

Shut Down

1. Set the thermostat to the lowest temperature setting.
2. Turn "OFF" all electric power to unit.
3. Open gas heat access panel.
4. Turn gas valve clockwise to "OFF" position (See Figure 33).

Checking Gas Heat Input

This unit has two stages of gas heat. The first stage is 60% of the full fire input and is considered the minimum input for the furnace. The intended input for each furnace is shown in Table 28. The table applies to units operating on 60 Hz power only.

To determine the rate of gas flow (Second Stage).

1. Turn off all other gas appliances connected to the gas meter.
2. Turn on the furnace and make sure the thermostat is calling for Second stage (100% input) heat.
3. Measure the time needed for one revolution of the hand on the smallest dial on the meter. A typical gas meter has a 1/2 or a 1 cubic foot test dial.
4. Using the number of seconds it takes for one revolution of the dial, calculate the cubic feet of gas consumed per hour. (See example below).
5. If necessary, adjust the high pressure regulator as discussed in the section "Manifold Gas Pressure Adjustment". **Be sure not to over-fire** the furnace on Second stage. If in doubt, it is better to leave the Second stage of the furnace slightly under-fired. Repeat Steps 1-5.

To determine the rate of gas flow (First Stage)

1. Turn off all other gas appliances connected to the gas meter.
2. Turn on the furnace and make sure the thermostat is calling for first stage (60% input) heat.
3. Even when the thermostat is calling for first stage heat, the unit will light on second stage and will run on Second stage for 1 minute. Allow this one-minute time period to expire and be certain the unit is running on first stage.
4. Measure the time needed for one revolution of the hand on the smallest dial on the meter. A typical gas meter has a 1/2 or a 1 cubic foot test dial.
5. Using the number of seconds it takes for one revolution of the dial, calculate the cubic feet of gas consumed per hour (See example below).
6. If necessary, adjust the low pressure regulator as discussed in the section "Manifold Gas Pressure Adjustment". **Be sure not to under-fire** the furnace on first

stage. If in doubt, it is better to leave the first stage of the furnace slightly over-fired (greater than 60% input). Repeat Steps 1-6.

Table 27: Gas Rate Cubic Feet Per Hour

Seconds for One Rev.	Size of Test Dial	
	1/2 cu. ft.	1 cu. ft.
10	180	360
12	150	300
14	129	257
16	113	225
18	100	200
20	90	180
22	82	164
24	75	150
26	69	138
28	64	129
30	60	120
32	56	113
34	53	106
36	50	100
38	47	95
40	45	90
42	43	86
44	41	82
46	39	78
48	37	75
50	36	72
52	35	69
54	34	67
56	32	64
58	31	62
60	30	60

NOTE: To find the Btu input, multiply the number of cubic feet of gas consumed per hour by the Btu content of the gas in your particular locality (contact your gas company for this information as it varies widely from area to area).

EXAMPLE

By actual measurement, it takes 19 seconds for the hand on a 1 cubic foot dial to make a revolution with a 192,000 Btuh furnace running. To determine rotations per minute, divide 60 by 19 = 3.16. To calculate rotations per hour, multiply 3.16 • 60 = 189.6. Multiply 189.6 • 1 (0.5 if using a 1/2 cubic foot dial) = 189.6. Multiply 189.6 • (the Btu rating of the gas). For this example, assume the gas has a Btu rating of 1050 Btu/ft.³. The result of 199,000 Btuh is within 5% of the 192,000 Btuh rating of the furnace.

Manifold Gas Pressure Adjustment

This gas furnace has two heat stages. Therefore, the gas valve has two adjustment screws located under a plastic protective cover. The second stage (100% input) adjustment screw is adjacent to the "HI" marking on the valve and the first stage (60% input) adjustment screw is located adjacent to the "LO" marking on the valve (See Figure 33).

Manifold pressure adjustment procedure.

Adjust second stage (100% input) pressure first, then adjust first stage (60% input) pressure.

1. Turn off all power to the unit.
2. Using the outlet pressure port on the gas valve, connect a manometer to monitor the manifold pressure.
3. Remove plastic cap covering HI and LO pressure adjustment screws.
4. Turn on power to the unit.
5. Set thermostat to call for second stage heat and start furnace.
6. If necessary, using a screwdriver, turn the second stage adjustment screw (adjacent to the "HI" marking on the valve) clockwise to increase manifold pressure or counterclockwise to decrease manifold pressure. **Be sure not to over-fire the unit on second stage.**
7. After the high manifold pressure has been checked, adjust the thermostat to call for first stage heat.
8. If necessary, using a screwdriver, turn the first stage adjustment screw (adjacent to the "LO" marking on the valve) clockwise to increase manifold pressure or counterclockwise to decrease manifold pressure. **Be sure not to under-fire the unit on first stage.**
9. Once pressure has been checked, replace the plastic cap covering the HI and LO pressure adjustment screws.

NOTE: When using natural gas, the manifold pressure for second stage (100% input) should be 3.5 IWG ± 0.3. The manifold pressure for first stage (60% input) when using natural gas should be 1.5 IWG ± 0.3.

Table 28: Gas Heat Stages

# of Burner Tubes	2nd Stage Input (100% Btuh)	1st Stage Input (60% Btuh)
4	120,000	72,000
6	180,000	108,000
8	240,000	144,000

Adjustment Of Temperature Rise

The temperature rise (the difference of temperature between the return air and the heated air from the furnace) must lie within the range shown on the CSA rating plate and the data in Table 9.

After the temperature rise has been determined, the CFM can be calculated as follows:

$$CFM = \text{Btu Input} \cdot \frac{0.8}{(1.08 \cdot \Delta^{\circ}F)}$$

After about 20 minutes of operation, determine the furnace temperature rise. Take readings of both the return air and the heated air in the ducts (about 6 feet from the furnace) where they will not be affected by radiant heat. Increase the blower CFM to decrease the temperature rise; decrease the blower CFM to increase the rise (See SUPPLY AIR DRIVE ADJUSTMENT).

NOTE: Each gas heat exchanger size has a minimum allowable CFM. Below this CFM, the limit will open.

Burners/Orifices Inspection/Serviceing

Before checking or changing burners, pilot or orifices, CLOSE MAIN MANUAL SHUT-OFF VALVE AND SHUT OFF ALL POWER TO THE UNIT.

1. Open the union fitting just upstream of the unit gas valve and downstream from the main manual shut-off valve in the gas supply line.
2. Remove the screws holding each end of the manifold to the manifold supports.
3. Disconnect wiring to the gas valves and spark igniter's. Remove the manifold & gas valve assembly. Orifices can now be inspected and/or replaced.

To service burners, complete step 4.

4. Remove the heat shield on top of the manifold supports. Burners are now accessible for inspection and/or replacement.

NOTE: Reverse the above procedure to replace the assemblies.

Make sure that burners are level and seat at the rear of the gas orifice.

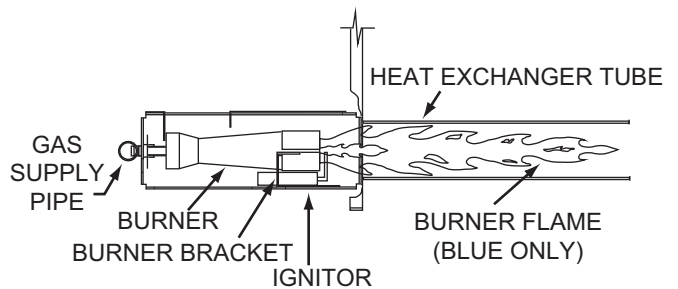

Figure 32: Typical Flame

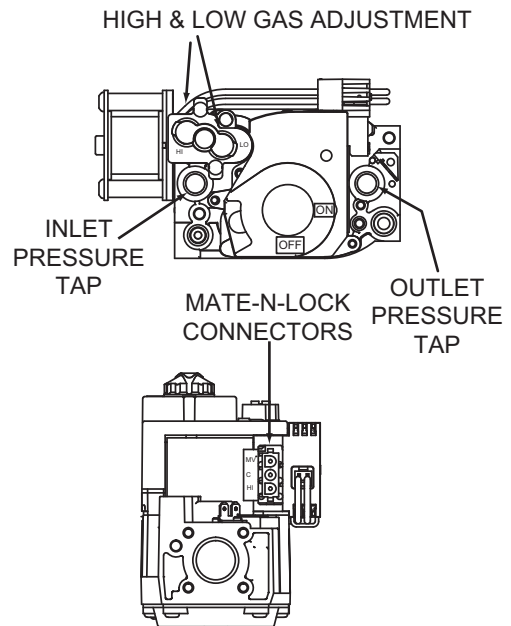

Figure 33: Typical Gas Valve

Charging The Unit

All ZJ units use Thermal Expansion Devices. Charge the unit to nameplate charge or 10° subcooling.

Control Board Navigation Components

The following components are needed to access the control points in the Simplicity® SE control. Installation and operation guides are located on www.upgnet.com under Product Center \ Equipment Catalog \ Commercial Products \ Zoning Systems and Controls.

1. Local LCD on Unit Control Board.
OR
2. Mobile Access Portal (MAP) Gateway (Portable).
 - Source 1 P/N S1-JC-MAP1810-OP
3. MAP Gateway Quick Start Guide P/N 24-10737-16
4. MAP Gateway Instruction P/N 24-10737-8

NOTE: For more in-depth sequence of operation of the Simplicity® SE control please refer to LIT-12011950 on www.upgnet.com under Product Center \ Equipment Catalog \ Commercial Products \ Zoning Systems and Controls.

SIMPLICITY™ SE (SMART EQUIPMENT) FIRMWARE VERSION 3. BASIC UNIT CONTROL BOARD NAVIGATION EXAMPLES:

The following document details the navigation and viewing of the LCD display screen equipped as a standard item on the Simplicity SE control installed within various commercial UPG packaged and split system equipment. The following information provides a step-by-step demonstration on how to

navigate the basic status menu and how to change basic configuration settings. The basic navigation steps outlined in this short demonstration applies to most menus within the Simplicity SE control.



Understanding the Local LCD

After you apply power to your Rooftop Unit (RTU), a start-up countdown begins on the Unit Control Board (UCB) LCD. When the controller is ready, the screen is blank because no faults are present. Use the joystick and the two push buttons below the LCD, to navigate through the menus.

Step 1 - After the start-up countdown is complete the first screen displayed is the "Status & Alarms" screen. When the cursor is on the top "Status" line hit the "ENTER" button. This action steps the LCD display into the status mode. Hit "ENTER" to view the status menu.



Step 2 - The first item under the status menu is "DVent-Mode". This is the demand ventilation mode.

Step 3 - When the cursor is on the "DVent-Mode" hit "ENTER" to view the status of this mode. In this case a CO2 sensor is not installed, thus Demand Ventilation or DVent is disabled.

Step 4 - To exit out of the "DVent-Mode status screen push "Cancel". The screen returns to that shown below.

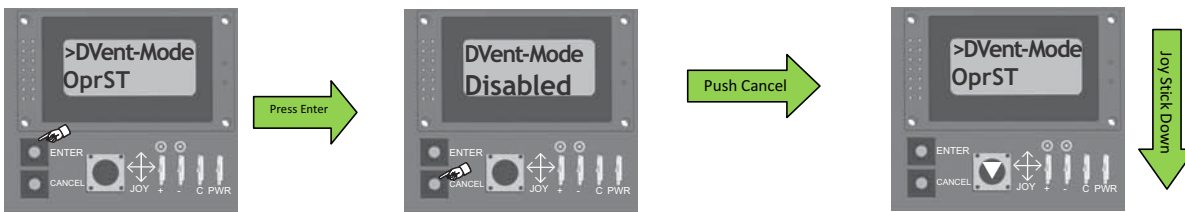

Step 5 - By pushing the joystick down, the cursor toggles to OprST (Operating Space Temp).

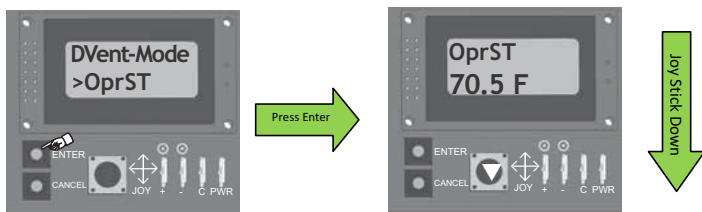

Step 6 - By pushing "ENTER" the actual OprST (Operating Space Temp) appears. Pushing the joystick down scrolls through SAT, RAT, OAT and other available sensor readings.

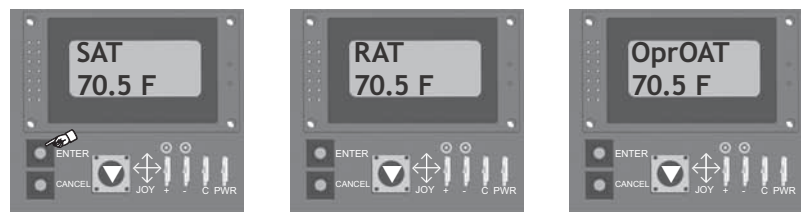

Press the "Cancel" button to exit each menu level. Repeatedly pressing "Cancel" returns the menu to the first "Status, Alarms" screen.

When the "Cancel" button is pressed multiple times to exit each menu level and the screen returns to the first "Status, Alarms" display the next demonstration can begin. In this demonstration the information below steps through the "Commissioning" menu.

Step 1- Beginning at the status/alarm screen toggle the joystick down three times. This accesses the "Commissioning" screen. In this menu section various settings can be changed. Please see the Unit Control Board menu for a list of parameters that can be modified.

Step 2- Once commission appears next to the cursor, press "ENTER" to begin viewing parameters.

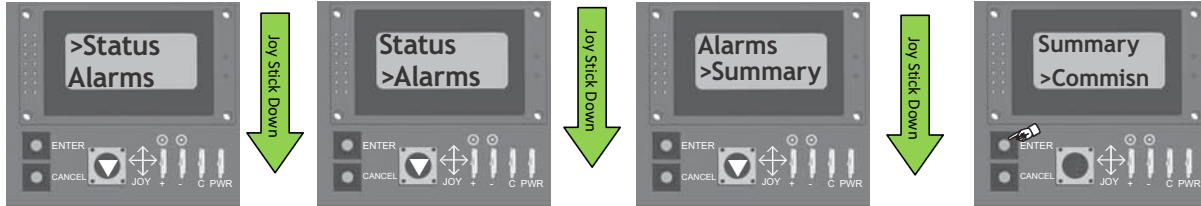

Step 3- After "ENTER" is pressed the various parameter sections appear, such as: HVAC zone, Indoor Fan, Clg, Htg, Econ and others.

Step 4- After toggling the joystick down two times "Clg" appears. This allows items, such as lead-lag and OCC/UNOCC cooling set points, to be changed.

Step 5- At the "Clg" screen once "ENTER" is pushed the status indicates if cooling is engaged/disengaged and lead-lag is engaged/disengaged.

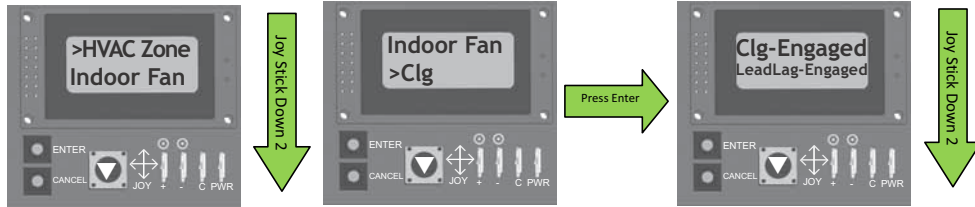

Step 6- By toggling down twice the screen reaches the "ClgOcc-SP" screen or "Cooling Occupied Set Point".

Step 7- After pressing "ENTER" at the "ClgOCC-SP" screen the space temperature set point appears. NOTE: Only applies to units controlled by a space sensor.

Step 8- In order to change set points push the toggle switch left or right. Note: The screen flashes. Left decreases the value, right increases. In this demonstration the ClgOCC setpoint is changed from 72F to 95F.



Step 9- The joystick was toggled right to increase the set point temperature. The screen flashes when in the change mode. Once the desired set point/value is reached press the "ENTER" button to save the value.

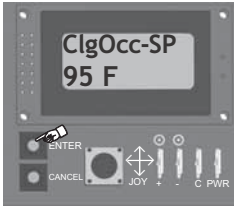

These few pages provide a simple demonstration how to navigate the menu's of the Simplicity SE control containing Version 3 firmware. Please utilize this document along with the additional information in the Users Guide and detailed navigation menu to adjust the control to customer preferences or job specifications.

NOTE: IF OPERATING THE EQUIPMENT WITH A THERMOSTAT, THE UCB SETPOINTS AND PARAMETERS SHOULD NOT REQUIRE ALTERATION; HOWEVER, THERE MAY BE THE CASE WHERE MINIMUM OUTSIDE AIR, LEAD-LAG OR OTHER CUSTOM SETTINGS ARE REQUIRED. PLEASE READ THIS DOCUMENT IN DETAIL TO UNDERSTAND THE IMPLICATIONS OF MAKING CHANGES BEFORE PROCEEDING. IT IS STRONGLY RECOMMENDED THAT A BACKUP OF PARAMETER SETTINGS BE SAVED ON A USB DRIVE BEFORE MAKING ANY MAJOR CHANGES TO THE CONTROL!



Figure 34: Unit Control Board

Table 29: Simplicity SE UCB Details

Description		Function & Comments
Terminal Directional orientation: viewed with silkscreen labels upright		
Limit, 24 VAC power and shutdown connections from unit wiring harness at left on upper edge of UCB		
LIMIT	Monitored 24 VAC input through heat section limit switch(es)	If voltage is absent, indicating the heat section is over-temperature, the UCB will bring on the indoor blower
C	24 VAC, 75 VA transformer Common referenced to cabinet ground	Connects through circuit traces to thermostat connection strip C and indoor blower VFD pin C
24V	24 VAC, 75 VA transformer hot	Powers the UCB microprocessor, connects through circuit trace to the SD 24 terminal
SD 24	24 VAC hot out for factory accessory smoke detector, condensate overflow and/or user shutdown relay switching in series	Connects through circuit trace to thermostat connection strip SD-24. A wiring harness jumper plug connecting SD 24 to SD R is in place if factory accessories for unit shutdown are not used - this jumper plug must be removed if the switching of field-added external accessories for unit shutdown are wired between thermostat connection strip SD-24 and R
SD R	24 VAC hot return from factory accessory smoke detector, condensate overflow and user shutdown relay switching in series	Connects through circuit trace to the R terminal on the upper left of the board
R	24 VAC hot for switched inputs to the UCB	Connects through circuit trace to the thermostat connection strip R terminal, right FAN OVR pin, right HPS1 pin, right HPS2 pin, lower DFS pin and lower APS pin

Table 29: Simplicity SE UCB Details (Continued)

Description		Function & Comments
Terminal Thermostat connection strip on left edge of UCB		
W1	1st stage heating request, 24 VAC input switched from R	Not effective for cooling-only units
W2	2nd stage heating request, 24 VAC input switched from R	Not effective for cooling-only units or units with single-stage heat sections
Y1	1st stage cooling request, 24 VAC input switched from R	
Y2	2nd stage cooling request, 24 VAC input switched from R	Visible in the display menu when the #ClgStgs parameter is set for 2 or more, also effective for economizer free cooling supply air temperature reset when the #ClgStgs parameter is set for 1 or more
G	Continuous indoor blower request, 24 VAC input switched from R	
OCC	Occupancy request, 24 VAC input switched from R	Must have the OccMode parameter set for External to be effective
X	Hard lockout indicator, 24 volt output to a light thermostat LED	
R	24 VAC hot for thermostat switching and power	If field-added external accessories for unit shutdown are used, 24 VAC hot return from smoke detector, condensate overflow and/or user shutdown relay switching in series
SD-24	If field-added external accessories for unit shutdown are used, 24 VAC hot out for smoke detector, condensate over-flow and/or user shutdown relay switching in series	Unit wiring harness jumper plug for factory shutdown accessories must be removed if the switching of field-added external accessories for unit shutdown are wired between thermo-stat connection strip SD-24 and R
C	24 VAC common for thermostat power	
LEDs on left edge of UCB		
POWER	Green UCB power indicator	Lit indicates 24 VAC is present at C and 24V terminals
FAULT	Red hard lockout, networking error and firmware error indicator	1/2 second on/off flashing indicates one or more alarm is currently active, 1/10th second on/off flashing indicates a networking error (polarity, addressing, etc.) or a firmware error (likely correctable with re-loading from USB flash drive)
SA BUS	Green UCB SA bus communication transmission indicator	Lit/flickering indicates UCB SA bus communication is currently active, off indicates the UCB is awaiting SA bus communication
Terminal Space temperature sensor connections at center on upper edge of UCB		
ST	Space Temperature sensor input from 10K Ω @ 77°F, Type III negative temperature coefficient thermistor	Positive of VDC circuit (3.625 VDC reading to COM with open circuit), effective if "Thermo-stat-only Control" parameter is set OFF, space sensor override momentarily shorts ST to COM to initiate/terminate temporary occupancy
COM	Common for ST and SSO inputs	Negative of VDC circuit for ST and SSO inputs
SSO	Space Sensor Offset input from 0 to 20K Ω potentiometer	Positive of VDC circuit (3.625 VDC reading to COM with open circuit), 10K Ω /2.5 VDC is 0°F offset, 0 Ω /0 VDC is maximum above offset and 20K Ω /3.4 VDC is maximum below offset from active space temperature setpoint
Pin Temperature sensor connections at right on upper edge of UCB		
SAT+	Supply Air Temperature sensor input from 10K Ω @ 77°F, Type III negative temperature coefficient thermistor	Input required for operation; 3.625 VDC reading SAT+ to SAT- with open circuit. Used in heat/cool staging cutouts, free cooling operation, demand ventilation operation, comfort ventilation operation, economizer loading operation, VAV cooling operation, hydronic heat operation.

Table 29: Simplicity SE UCB Details (Continued)

Description		Function & Comments
RAT+	Return Air Temperature sensor input from 10KΩ @ 77°F, Type III negative temperature coefficient thermistor	Input required for operation; 3.625 VDC reading RAT+ to RAT- with open circuit. Used in return air enthalpy calculation. Substitutes for space temperature if no other space temperature input is present.
OAT+	Outside Air Temperature sensor input from 10KΩ @ 77°F, Type III negative temperature coefficient thermistor	Input required for operation but may be a communicated value; 3.625 VDC reading OAT+ to OAT- with open circuit. Used in heat/cool cutouts, low ambient cooling determination, dry bulb free cooling changeover, outside air enthalpy calculation, economizer loading operation, heat pump demand defrost calculation.
CC1+	#1 refrigerant circuit Condenser Coil temperature sensor input from 10KΩ @ 77°F, Type III negative temperature coefficient thermistor	Input required for heat pump units, not required for A/C units; 3.625 VDC reading CC1+ to CC1- with open circuit. Used in heat pump demand defrost calculation.
EC1+	#1 refrigerant circuit Evaporator Coil temperature sensor input from 10KΩ @ 77°F, Type III negative temperature coefficient thermistor	Input required for operation; 3.625 VDC reading EC1+ to EC1- with open circuit. Used in suction line temperature safety.
CC2+	#2 refrigerant circuit Condenser Coil temperature sensor input from 10KΩ @ 77°F, Type III negative temperature coefficient thermistor	Input required for 2-compressor heat pump units, not required for 2-compressor A/C units, not active for 1-compressor units; 3.625 VDC reading CC2+ to CC2- with open circuit. Used in heat pump demand defrost calculation.
EC2+	#2 refrigerant circuit Evaporator Coil temperature sensor input from 10KΩ @ 77°F, Type III negative temperature coefficient thermistor	Input required for operation of 2-compressor units, not active for 1-compressor units; 3.625 VDC reading EC2+ to EC2- with open circuit. Used in suction line temperature safety.
Pinned connections on right edge of UCB		
RAH+	Return Air Humidity input from 0-10 VDC @ 0-100% RH sensor	Input required for reheat units, optional in all other units, may be a communicated value. Used in return air enthalpy calculation, temperature/humidity setpoint reset, reheat operation.
DCT PRS+	Supply Duct Pressure input from 0-10 VDC @ 0-5" w.c. sensor	Input required for variable air volume units. Used in VAV indoor blower operation.
DFS (upper pin)	24 VAC hot return from Dirty Filter Switch	Optional input; switch closure for greater than 15 seconds during indoor blower operation initiates a notification alarm
DFS (lower pin)	24 VAC hot out for Dirty Filter Switch	Connects through circuit trace to the R terminal
APS (upper pin)	24 VAC hot return from Air Proving Switch	When this optional input is enabled: the air proving switch must close within 30 seconds of initiation of indoor blower operation and not open for greater than 10 seconds during indoor blower operation to allow heat/cool operation and prevent an "APS open" alarm; the air proving switch must open within 30 seconds of termination of indoor blower operation to prevent an "APS stuck closed" notification alarm
APS (lower pin)	24 VAC hot out for Air Proving Switch	Connects through circuit trace to the R terminal
C	Common for the VFD output	Negative of the VDC circuit for the VFD output
VFD	2-10 VDC (0-100%) output for the indoor blower Variable Frequency Drive	Output is active with indoor blower operation. For CV units: this output provides stepped IntelliSpeed control of the indoor blower VFD based on fan-only, cooling stage and heating stage outputs. For VAV units: this output provides control of the indoor blower VFD based on supply duct static pressure input and setpoint.

Table 29: Simplicity SE UCB Details (Continued)

Description		Function & Comments
VFDFLT	24 VAC hot input from the normally open VFD alarm contact	The VFD alarm contact switches from R within the unit wiring harness. 24 VAC input results in unit shutdown and a "VFD fault" alarm
Terminal at lower right corner of UCB		
24V FOR OUTPUTS	24 VAC hot for H1, H2, CN-FAN, AUX HGR, FAN C1 and C2 output relay contact switching	Output relay circuitry is isolated from other UCB components and the 24 VAC hot source may be from a second transformer in the unit
Pin Heat section connections at right on lower edge of UCB		
H1	24 VAC hot output for heat section stage 1	Not effective for cooling-only units. Output if demand is present and permissions allow one stage or two stages of heat section operation
H2	24 VAC hot output for heat section stage 2	Not effective for cooling-only units or units with single-stage heat sections. Output if demand is present and permissions allow two stages of heat section operation
MV	24 VAC hot input confirming heat section operation	Sourced from gas valve in gas heat units or first stage heat contactor in electric heat units. Input within 5 minutes from initiation of H1 output initiates the "Heat On Fan Delay" timer, loss of input following the termination of H1 output initiates the "Heat On Fan Delay" timer, no input within 5 minutes from initiation of H1 output initiates an "Ignition Failure" alarm, input for longer than 5 minutes without H1 output initiates a "Gas Valve Mis-wire" alarm
Pin Cooling and fan output connections at right on lower edge of UCB		
CN-FAN	24 VAC hot output for the condenser fan contactor coil	Output with either C1 or C2 output; interrupted during defrost cycle for heat pump units
AUX HGR	24 VAC hot output for hot gas reheat components	Effective only for reheat units, output with reheat operation
FAN	24 VAC hot output for indoor blower contactor coil/indoor blower VFD enable relay coil	Output with heat/cool operation, G input or schedule demand
C1	24 VAC hot output for compressor 1	If demand is present and permissions allow compressor 1 operation; output with compressor cooling, comfort ventilation cooling, reheat or heat pump heating demands
C2	24 VAC hot output for compressor 2	Not effective for one stage compressor UCBs. If demand is present and permissions allow compressor 2 operation; output with compressor cooling, comfort ventilation cooling or heat pump heating demands
Pin Refrigerant circuit safety switch and indoor blower overload connections at center on lower edge of UCB		
HPS1 (right pin)	24 VAC hot out for refrigerant circuit 1 High Pressure Switch	Connects through circuit trace to the R terminal
HPS1 (left pin)	24 VAC hot return from refrigerant circuit 1 High Pressure Switch	Input is only considered if C1 output is needed; input must be present to allow C1 output. Three HPS1 trips in a two hour period cause a "High Pressure Switch 1 Lockout" and C1 output is then prevented until alarm reset. Connects through circuit trace to the right LPS1 pin.
LPS1 (right pin)	24 VAC hot out for refrigerant circuit 1 Low Pressure Switch	Connects through circuit trace to the left HSP1 pin
LPS1 (left pin)	24 VAC hot return from refrigerant circuit 1 Low Pressure Switch	Input is only considered after 30 seconds of C1 output; afterwards, input must be present to allow C1 output. Three LPS1 trips in a one hour period cause a "Low Pressure Switch 1 Lockout" and C1 output is then prevented until alarm reset.

Table 29: Simplicity SE UCB Details (Continued)

Description		Function & Comments
HPS2 (right pin)	24 VAC hot out for refrigerant circuit 2 High Pressure Switch	Not effective for one stage compressor UCBs. Connects through circuit trace to the R terminal
HPS2 (left pin)	24 VAC hot return from refrigerant circuit 2 High Pressure Switch	Not effective for one stage compressor UCBs. Input is only considered if C2 output is needed; input must be present to allow C1 output. Three HPS2 trips in a two hour period cause a "High Pressure Switch 1 Lockout" and C2 output is then prevented until alarm reset. Connects through circuit trace to the right LPS2 pin.
LPS2 (right pin)	24 VAC hot out for refrigerant circuit 2 Low Pressure Switch	Not effective for one stage compressor UCBs. Connects through circuit trace to the left HSP2 pin
LPS2 (left pin)	24 VAC hot return from refrigerant circuit 2 Low Pressure Switch	Not effective for one stage compressor UCBs. Input is only considered after 30 seconds of C2 output; afterwards, input must be present to allow C2 output. Three LPS2 trips in a one hour period cause a "Low Pressure Switch 2 Lockout" and C2 output is then prevented until alarm reset.
FAN OVR (right pin)	24 VAC hot out for indoor blower FAN Overload relay contact/motor protector switch	Connects through circuit trace to the R terminal
FAN OVR (left pin)	24 VAC hot return from indoor blower FAN Overload relay contact/motor protector switch	Input is only considered if FAN output is needed; input must be present to allow FAN output and unit operation. One FAN OVR trip lasting longer than 5 minutes or three FAN OVR trips in a two hour period cause a "Fan Overload Lockout" and unit operation is then prevented until alarm reset.
Terminal SA BUS connections on at left on lower edge and center of UCB		
PWR	Power for SA ("Sensor-Actuator") BUS devices	Also incorporated in the J8 6-pin phone jack connector at the left-center of the board. Positive of the 15 VDC (reading to C) circuit for powering an optional netstat and/or Multi Touch gateway
C	Common for SA BUS power and communication circuits	Also incorporated in the J8 6-pin phone jack connector at the left-center of the board. Negative of the SA BUS circuits
-	Communication for SA BUS devices	Also incorporated in the J8 6-pin phone jack connector at the left-center of the board. Positive of the VDC (typically, a fluctuating 1.5 to 3.5 volts reading to C; at least 0.25 volts lower than +) SA BUS communication circuit to optional economizer board, 4-stage board, fault detection & diagnostics board, netstat and/or Multi Touch gateway
+	Communication for SA BUS devices	Also incorporated in the J8 6-pin phone jack connector at the left-center of the board. Positive of the VDC (typically, a fluctuating 1.5 to 3.5 volts reading to C; at least 0.25 volts higher than -) SA BUS communication circuit to optional economizer board, 4-stage board, fault detection & diagnostics board, netstat and/or Multi Touch gateway
J8	6-pin phone jack connector	Incorporates the SA BUS terminals for convenience/alternate connection of SA BUS devices, primarily used for temporary service connection of the Multi Touch gateway
Item Integrated user interface at lower left corner of UCB		
Display	On-board, 2-line x 8-character back-lit display	On-board display, buttons and joystick allow access to UCB, economizer, 4-stage and FDD board parameters
ENTER	Button for display menu acknowledgment and navigation	
CANCEL	Button for display menu navigation and zeroing of active compressor ASCD timer	
JOY	4-way Joystick for display menu navigation	

Table 29: Simplicity SE UCB Details (Continued)

Description		Function & Comments
Item USB connector at right of UCB		
J10	Type A female Universal Serial Bus connector	Used for backup, restoration, & copying of board parameters as well as board software updating through a flash drive
J15	Factory wired SA Bus connector	
Optional communication sub-board at center of UCB		
Terminal FC BUS connections on left edge of the communication board		
FC+	FC ("Field Connected") BUS BACnet MSTP communication	Positive of the VDC (typically, a fluctuating 1.5 to 3.5 volts reading to COM; at least 0.25 volts higher than -) FC bus BACnet MSTP communication circuit
FC-	FC ("Field Connected") BUS BACnet MSTP communication	Positive of the VDC (typically, a fluctuating 1.5 to 3.5 volts reading to COM; at least 0.25 volts lower than +) FC bus BACnet MSTP communication circuit
COM	Common for the FC ("Field Connected") BUS BACnet MSTP communication circuit	Negative of the VDC FC bus BACnet MSTP communication circuit
SHLD	Shield for the FC ("Field Connected") BUS BACnet MSTP communication circuit	Earth ground reference of the cable to prevent interference on the FC bus BACnet MSTP communication circuit
Item Selector in red housing at left on top edge of the communication board		
EOL switch	End Of Line selector switch for the FC BUS BACnet MSTP communication circuit	ON selected only for the UCB that is the terminus of the FC bus BACnet MSTP communication cable to prevent signal "bounce-back"
LEDs on the communication board		
EOL	Green End Of Line indicator	Lit indicates the EOL switch is selected ON
FC BUS	Green FC bus communication transmission indicator	Lit/flickering indicates outgoing UCB FC bus communication is currently active, off indicates the UCB is awaiting incoming FC bus communication
ISO PWR	Green communication board Isolated Power indicator	Lit indicates the UCB is supplying power to the communication sub-board

Table 30: Ignition Control Flash Codes

Flashes	Fault Conditions	Check
STEADY ON	Control Failure	Control
HEARTBEAT	Normal Operation	
1	Not Applicable	
2	Pressure Switch Stuck Closed	Pressure Switch
3	Pressure Switch Failed To Close	Venter Pressure Switch Vent Blocked
4	Limit Switch Open	Main Limit AUX Limit
5	Flame Present With Gas Off First Stage Gas Valve Energized With W1 Off Second Stage Gas Valve Energized With First Stage Gas Valve Off	Gas Valve
6	Ignition Lockout	Gas Flow Gas Pressure Gas Valve Flame Sensor
STEADY OFF	No Power Or Control Failure	24VAC or Control

Start-Up Sheet**START-UP & SERVICE DATA INSTRUCTION****COMMERCIAL PACKAGE UNITS****3.0 To 40.0 TONS****START-UP CHECKLIST**

Date: _____

Job Name: _____

Customer Name: _____

Address: _____

City: _____ State: _____ Zip: _____

Model Number: _____ Serial Number: _____

Qualified Start-up Technician: _____ Signature: _____

HVAC Contractor: _____ Phone: _____

Address: _____

Contractor's E-mail Address: _____

Electrical Contractor: _____ Phone: _____

Distributor Name: _____ Phone: _____

WARRANTY STATEMENT

Johnson Controls/UPG is confident that this equipment will operate to the owner's satisfaction if the proper procedures are followed and checks are made at initial start-up. This confidence is supported by the 30 day dealer protection coverage portion of our standard warranty policy which states that Johnson Controls/UPG will cover parts and labor on new equipment start-up failures that are caused by a defect in factory workmanship or material, for a period of 30 days from installation. Refer to current standard warranty policy and warranty manual found on UPGnet for details.

In the event that communication with Johnson Controls/UPG is required regarding technical and/or warranty concerns, all parties to the discussion should have a copy of the equipment start-up sheet for reference. A copy of the original start-up sheet should be filed with the Technical Services Department.

The packaged unit is available in constant or variable air volume versions with a large variety of custom options and accessories available. Therefore, some variation in the startup procedure will exist depending upon the products capacity, control system, options and accessories installed.

This start-up sheet covers all startup check points common to all package equipment. In addition it covers essential startup check points for a number of common installation options. Depending upon the particular unit being started not all sections of this startup sheet will apply. Complete those sections applicable and use the notes section to record any additional information pertinent to your particular installation.

Warranty claims are to be made through the distributor from whom the equipment was purchased.

EQUIPMENT STARTUP

Use the local LCD or Mobile Access Portal (MAP) Gateway to complete the start-up.

A copy of the completed start-up sheet should be kept on file by the distributor providing the equipment and a copy sent to:

Johnson Controls/UPG
Technical Services Department
5005 York Drive
Norman, OK 73069

1034349-UCL-C-0315

SAFETY WARNINGS

The inspections and recording of data outlined in this procedure are required for start-up of Johnson Controls/UPG's packaged products. Industry recognized safety standards and practices must be observed at all times. General industry knowledge and experience are required to assure technician safety. It is the responsibility of the technician to assess all potential dangers and take all steps warranted to perform the work in a safe manner. By addressing those potential dangers, prior to beginning any work, the technician can perform the work in a safe manner with minimal risk of injury.

 WARNING
Lethal voltages are present during some start-up checks. Extreme caution must be used at all times.

 WARNING
Moving parts may be exposed during some startup checks. Extreme caution must be used at all times.

NOTE: Read and review this entire document before beginning any of the startup procedures.

DESIGN APPLICATION INFORMATION

This information will be available from the specifying engineer who selected the equipment. If the system is a VAV system the CFM will be the airflow when the remote VAV boxes are in the

full open position and the frequency drive is operating at 60 HZ. **Do not proceed with the equipment start-up without the design CFM information.**

Design Supply Air CFM: _____ Design Return Air CFM: _____

Design Outdoor Air CFM At Minimum Position: _____

Total External Static Pressure: _____

Supply Static Pressure: _____

Return Static Pressure: _____

Design Building Static Pressure: _____

Outside Air Dilution: Economizer Position Percentage: _____ CFM: _____

Supply Gas Pressure After Regulator W/o Heat Active _____ Inches _____

ADDITIONAL APPLICATION NOTES FROM SPECIFYING ENGINEER:

1034349-UCL-C-0315

REFERENCE

General Inspection	Completed	See Notes
Unit inspected for shipping, storage, or rigging damage	<input type="checkbox"/>	<input type="checkbox"/>
Unit installed with proper clearances	<input type="checkbox"/>	<input type="checkbox"/>
Unit installed within slope limitations	<input type="checkbox"/>	<input type="checkbox"/>
Refrigeration system checked for gross leaks (presence of oil)	<input type="checkbox"/>	<input type="checkbox"/>
Terminal screws and wiring connections checked for tightness	<input type="checkbox"/>	<input type="checkbox"/>
Filters installed correctly and clean	<input type="checkbox"/>	<input type="checkbox"/>
Economizer hoods installed in operating position	<input type="checkbox"/>	<input type="checkbox"/>
Condensate drain trapped properly, refer to Installation Manual	<input type="checkbox"/>	<input type="checkbox"/>
Economizer damper linkage tight	<input type="checkbox"/>	<input type="checkbox"/>
Gas Heat vent hood installed	<input type="checkbox"/>	<input type="checkbox"/>
All field wiring (power and control) complete	<input type="checkbox"/>	<input type="checkbox"/>

Air Moving Inspection	Completed	See Notes
Alignment of drive components	<input type="checkbox"/>	<input type="checkbox"/>
Belt tension adjusted properly	<input type="checkbox"/>	<input type="checkbox"/>
Blower pulleys tight on shaft, bearing set screws tight, wheel tight to shaft	<input type="checkbox"/>	<input type="checkbox"/>
Pressure switch or transducer tubing installed properly	<input type="checkbox"/>	<input type="checkbox"/>

Exhaust Inspection	Powered <input type="checkbox"/>	Barometric Relief <input type="checkbox"/>	Completed	See Notes
Check hub for tightness			<input type="checkbox"/>	<input type="checkbox"/>
Check fan blade for clearance			<input type="checkbox"/>	<input type="checkbox"/>
Check for proper rotation			<input type="checkbox"/>	<input type="checkbox"/>
Check for proper mounting (screen faces towards unit)			<input type="checkbox"/>	<input type="checkbox"/>
Prove operation by increasing minimum setting on economizer			<input type="checkbox"/>	<input type="checkbox"/>

Economizer Inspection	Standard <input type="checkbox"/>	BAS <input type="checkbox"/>	Completed	See Notes
CO ₂ sensor installed Yes <input type="checkbox"/> No <input type="checkbox"/>			<input type="checkbox"/>	<input type="checkbox"/>
Check economizer setting (Reference SSE Control Board LCD menu location)			<input type="checkbox"/>	<input type="checkbox"/>
Prove economizer open/close through SSE Board Setting			<input type="checkbox"/>	<input type="checkbox"/>

Reheat Mode	Normal <input type="checkbox"/>	or Alternate <input type="checkbox"/>	Not Applicable <input type="checkbox"/>
Humidity Sensor (2SH0401) _____			

Operating Measurements - Air Flow

Fan operates with proper rotation	ID Fans <input type="checkbox"/>	Exh. Fans <input type="checkbox"/>	Cond. Fans <input type="checkbox"/>
Pressure drop across dry evaporator coil (At maximum design CFM) ¹			IWC
External Static Pressure			IWC
Return Static Pressure			IWC
Supply Static Pressure			IWC
Supply Air CFM Using Dry Coil Chart			CFM
Final Adjusted Supply Air CFM ²			CFM

1. Consult the proper airflow to pressure drop table to obtain the actual airflow at the measured pressure differential.
2. Was a motor pulley adjustment or change required to obtain the correct airflow?
Was it necessary to increase or decrease the airflow to meet the design conditions?
If the motor pulley size was changed, measure the outside diameters of the motor and blower pulleys and record those diameters here;

Blower Motor HP _____ FLA _____ RPM _____

Pulley Pitch Diameter _____ Turns Out _____ Final Turns Out _____

Blower Pulley Pitch Diameter _____ Fixed Sheave _____

ELECTRICAL DATA

T1 - T2 _____ Volts T2 - T3 _____ Volts
Control Voltage _____ Volts T1 - T3 _____ Volts

Device	Nameplate	Measured List All Three Amperages
Supply Fan Motor ^{1, 2}	AMPS	AMPS
Exhaust Motor (Dampers 100%)	AMPS	AMPS
Condenser Fan #1	AMPS	AMPS
Condenser Fan #2 (if equipped)	AMPS	AMPS
Condenser Fan #3 (if equipped)	AMPS	AMPS
Condenser Fan #4 (if equipped)	AMPS	AMPS
Compressor #1	AMPS	AMPS
Compressor #2 (if equipped)	AMPS	AMPS
Compressor #3 (if equipped)	AMPS	AMPS
Compressor #4 (if equipped)	AMPS	AMPS

1. VAV units with heat section - simulate heat call to drive VAV boxes and VFD/IGV to maximum design airflow position.
2. VAV units without heat section - VAV boxes must be set to maximum design airflow position.

1034349-UCL-C-0315

OPERATING MEASUREMENTS - COOLING

Stage	Discharge Pressure	Discharge Temp.	Liquid Line Temp. ¹	Subcooling ²	Suction Pressure	Suction Temp.	Superheat
First	#	°	°	°	#	°	°
Second (if equipped)	#	°	°	°	#	°	°
Third (if equipped)	#	°	°	°	#	°	°
Fourth (if equipped)	#	°	°	°	#	°	°
Reheat 1st Stage	#	°	°	°	#	°	°

- Liquid temperature should be taken before filter/drier.
- Subtract 10 psi from discharge pressure for estimated liquid line pressure

Outside air temperature _____ °F db _____ °F wb _____ %RH
 Return Air Temperature _____ °F db _____ °F wb _____ %RH
 Mixed Air Temperature _____ °F db _____ °F wb _____ %RH
 Supply Air Temperature _____ °F db _____ °F wb _____ %RH

REFRIGERANT SAFETIES

Action	Completed	See Notes
Prove Compressor Rotation (3 phase only) by gauge pressure	<input type="checkbox"/>	<input type="checkbox"/>
Prove High Pressure Safety, All Systems	<input type="checkbox"/>	<input type="checkbox"/>
Prove Low Pressure Safety, All Systems	<input type="checkbox"/>	<input type="checkbox"/>

OPERATING MEASUREMENTS - GAS HEATING

Fuel Type: Natural Gas LP Gas

Action	Completed	See Notes
Check for gas leaks	<input type="checkbox"/>	<input type="checkbox"/>
Prove Ventor Motor Operation	<input type="checkbox"/>	<input type="checkbox"/>
Prove Primary Safety Operation	<input type="checkbox"/>	<input type="checkbox"/>
Prove Auxiliary Safety Operation	<input type="checkbox"/>	<input type="checkbox"/>
Prove Rollout Switch Operation	<input type="checkbox"/>	<input type="checkbox"/>
Prove Smoke Detector Operation	<input type="checkbox"/>	<input type="checkbox"/>
Manifold Pressure	Stage 1	IWC <input type="checkbox"/>
	Stage 2 (If Equipped)	IWC <input type="checkbox"/>
	Stage 3 (If Equipped)	IWC <input type="checkbox"/>
Supply gas pressure at full fire	IWC	<input type="checkbox"/>
Check temperature rise ¹	<input type="checkbox"/> measured at full fire	°F <input type="checkbox"/>

1. $\frac{\text{Input X Eff. (BTU output)}}{1.08 \text{ X Temp. Rise}}$

OPERATIONAL MEASUREMENTS - STAGING CONTROLS

Verify Proper Operation of Heating/Cooling Staging Controls	
Create a cooling demand at the Thermostat, BAS System or Simplicity SE Verify that cooling/economizer stages are energized.	<input type="checkbox"/>
Create a heating demand at the Thermostat, BAS System or Simplicity SE Verify that heating stages are energized.	<input type="checkbox"/>
Verify Proper Operation of the Variable Frequency Drive (If Required)	
Verify that motor speed modulates with duct pressure change.	<input type="checkbox"/>

FINAL - INSPECTION

Verify that all operational control set points have been set to desired value Scroll through all setpoints and change as may be necessary to suit the occupant requirements.	<input type="checkbox"/>
Verify that all option parameters are correct Scroll through all option parameters and ensure that all installed options are enabled in the software and all others are disabled in the software. (Factory software settings should match the installed options)	<input type="checkbox"/>
Verify that all access panels have been closed and secured	<input type="checkbox"/>

OBSERVED PRODUCT DIFFICIENCIES & CONCERNS:
